

# Roofit

- *Introduction*
- *Basic functionality*
- *Addition and convolution*
- *Building multidimensional models*
- *Managing data, discrete variables and simultaneous fits*
- *More on likelihood calculation and minimization*
- *Validation studies*

# 1 Introduction & Overview

- *Introduction*
- *Some basics statistics*
- *Roofit design philosophy*

# Introduction – Purpose

---

Model the distribution of observables  $\vec{x}$  in terms of

- Physical parameters of interest  $\vec{p}$
- Other parameters  $\vec{q}$  to describe detector effects  
(resolution, efficiency, ...)



Probability density function  $F(\vec{x}; \vec{p}, \vec{q})$

- normalized over allowed range of the observables  $\mathbf{x}$   
w.r.t the parameters  $\mathbf{p}$  and  $\mathbf{q}$

## Introduction -- Focus: coding a probability density function

---

- Focus on one practical aspect of many data analysis in HEP: **How do you formulate your p.d.f. in ROOT**
  - For 'simple' problems (gauss, polynomial), ROOT built-in models well sufficient

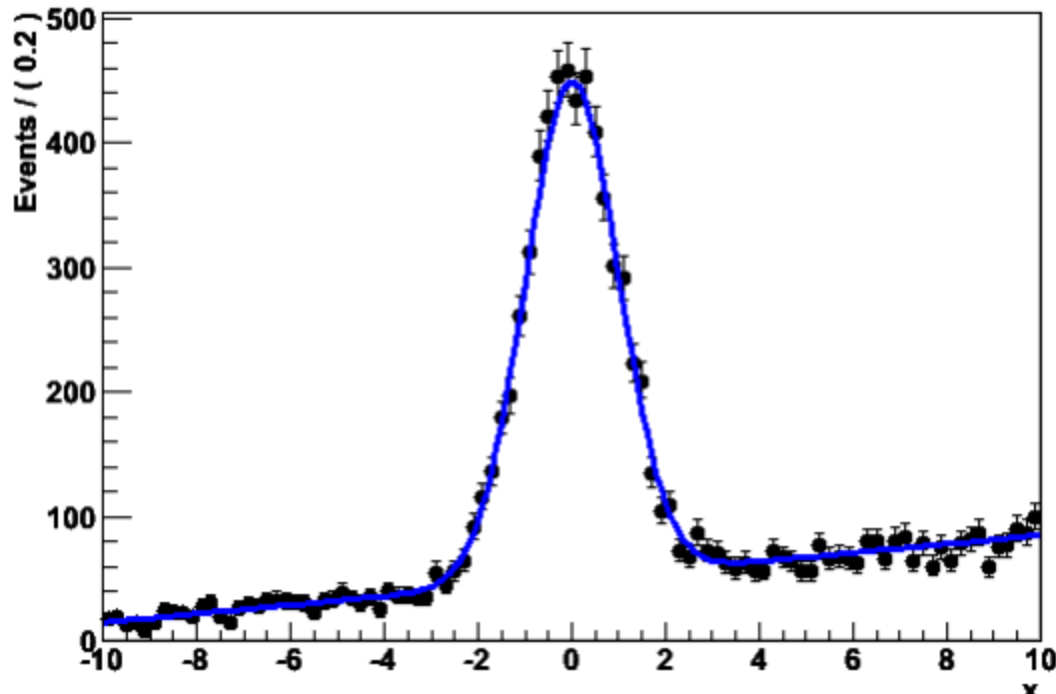

- But if you want to do unbinned ML fits, use non-trivial functions, or work with multidimensional functions you are quickly running into trouble

# Introduction – Relation to ROOT

Extension to ROOT – (Almost) no overlap with existing functionality

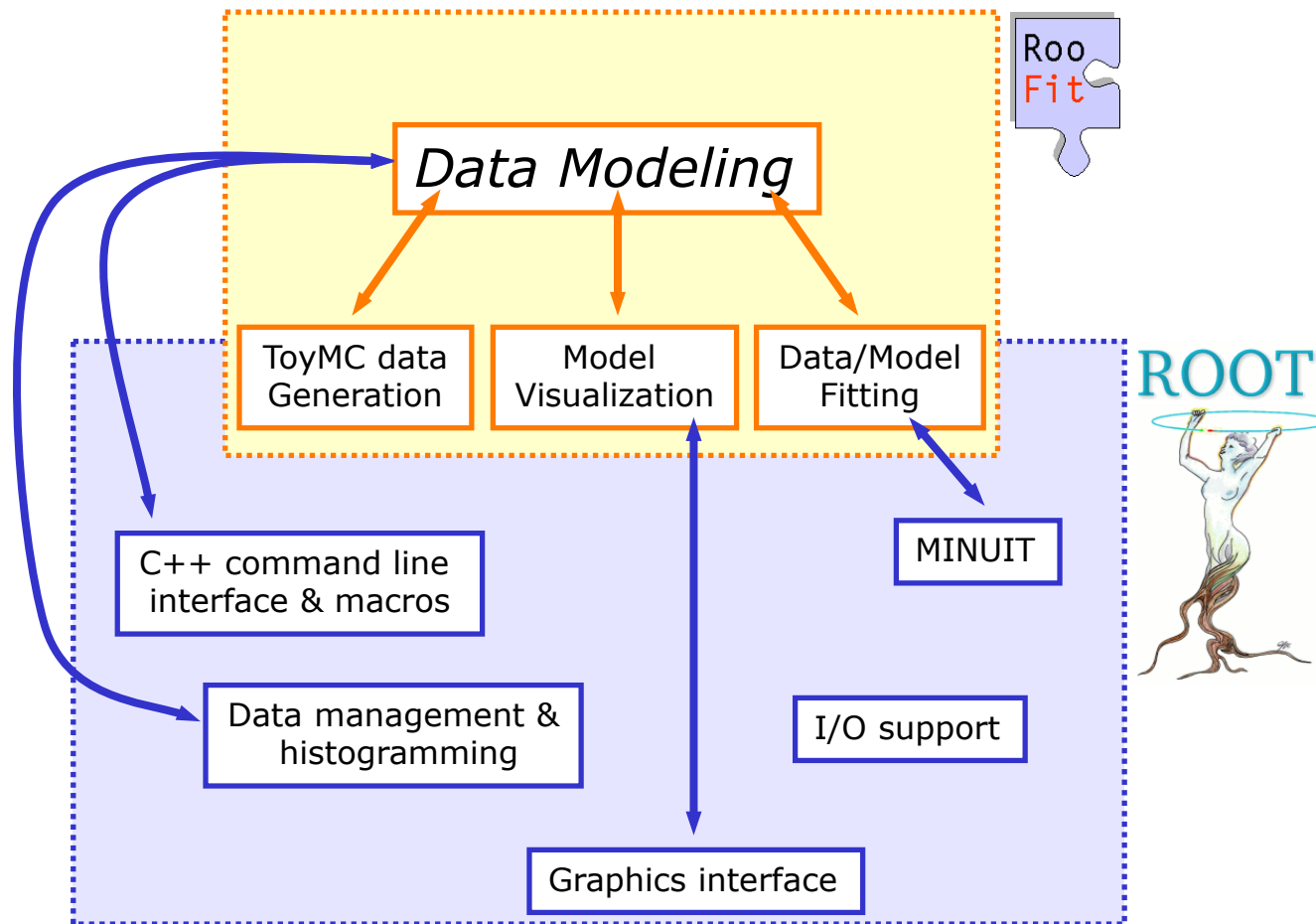

# Introduction – Why RooFit was developed

---

- **BaBar experiment at SLAC:** Extract  $\sin(2\beta)$  from time dependent CP violation of B decay:  $e^+e^- \rightarrow Y(4s) \rightarrow B\bar{B}$ 
  - Reconstruct both Bs, measure decay time difference
  - Physics of interest is in decay time dependent oscillation

$$f_{sig} \cdot \left[ \text{SigSel}(m; \bar{p}_{sig}) \cdot \left( \text{SigDecay}(t; \vec{q}_{sig}, \sin(2\beta)) \otimes \text{SigResol}(t | dt; \vec{r}_{sig}) \right) \right] + (1 - f_{sig}) \left[ \text{BkgSel}(m; \bar{p}_{bkg}) \cdot \left( \text{BkgDecay}(t; \vec{q}_{bkg}) \otimes \text{BkgResol}(t | dt; \vec{r}_{bkg}) \right) \right]$$

- Many issues arise
  - Standard ROOT function framework clearly insufficient to handle such complicated functions → **must develop new framework**
  - **Normalization of p.d.f. not always trivial to calculate** → may need numeric integration techniques
  - Unbinned fit, >2 dimensions, many events → computation performance important → **must try optimize code** for acceptable performance
  - Simultaneous fit to control samples to account for detector performance

# Mathematic – Probability density functions

- Probability Density Functions describe probabilities, thus
  - All values must be  $>0$
  - The total probability must be 1 *for each*  $p$ , i.e.
  - Can have any number of dimensions

$$\int_{\bar{x}_{\min}}^{\bar{x}_{\max}} g(\bar{x}, \bar{p}) d\bar{x} \equiv 1$$

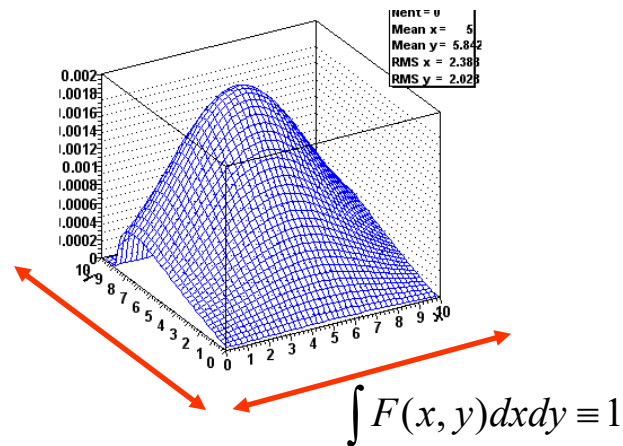
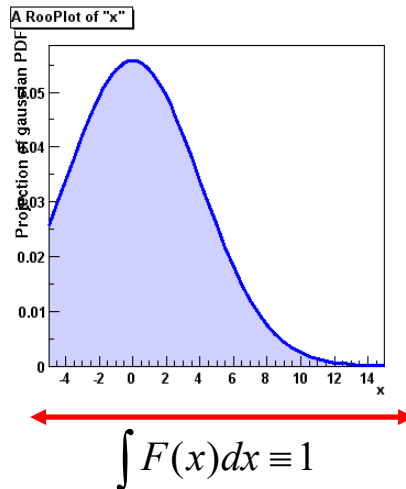

- Note distinction in role between *parameters* ( $p$ ) and *observables* ( $x$ )
  - Observables are measured quantities
  - Parameters are degrees of freedom in your model

# Math – Functions vs probability density functions

- Why use *probability density* functions rather than 'plain' functions to describe your data?
  - *Easier to interpret your models.*  
If Blue and Green pdf are each guaranteed to be normalized to 1, then fractions of Blue, Green can be cleanly interpreted as #events
  - *Many statistical techniques only function properly with PDFs* (e.g maximum likelihood)
  - *Can sample 'toy Monte Carlo' events* from p.d.f because value is always guaranteed to be  $\geq 0$
- So why is not everybody always using them
  - *The normalization can be hard to calculate* (e.g. it can be different for each set of parameter values  $p$ )
  - *In  $>1$  dimension (numeric) integration can be particularly hard*
  - RooFit aims to simplify these tasks

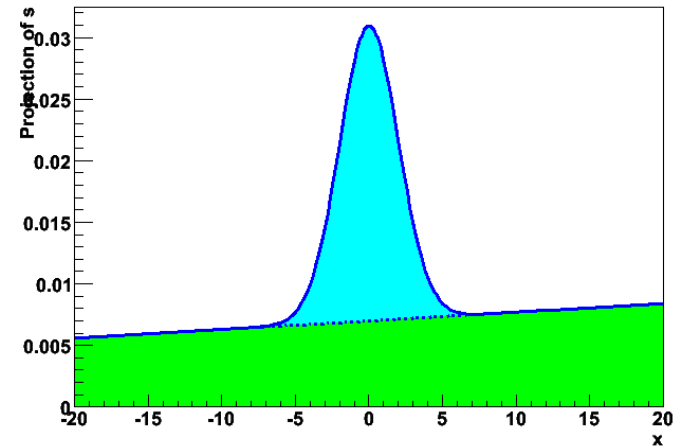



# Math – Event generation

---

- For every p.d.f, can generate 'toy' event sample as follows
  - Determine maximum PDF value by repeated random sample
  - Throw a uniform random value ( $x$ ) for the observable to be generated
  - Throw another uniform random number between 0 and  $f_{\max}$   
If  $\text{ran} * f_{\max} < f(x)$  accept  $x$  as generated event
  - *More efficient techniques exist (discussed later)*

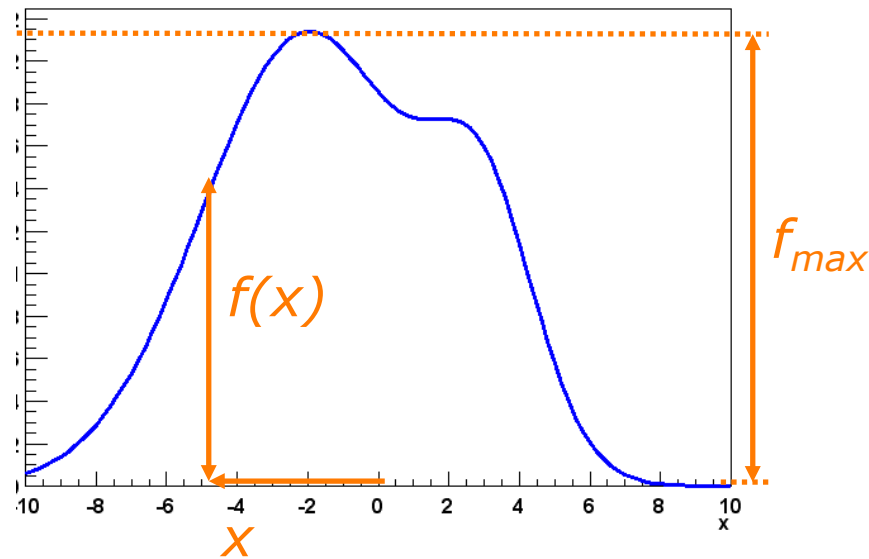

# Math – What is an estimator?

---

- An **estimator** is a **procedure** giving a value for a parameter or a property of a distribution as a function of the actual data values, i.e.

$$\hat{\mu}(x) = \frac{1}{N} \sum_i x_i \quad \leftarrow \text{Estimator of the mean}$$

$$\hat{V}(x) = \frac{1}{N} \sum_i (x_i - \bar{\mu})^2 \quad \leftarrow \text{Estimator of the variance}$$

- A perfect estimator is
  - **Consistent:**  $\lim_{n \rightarrow \infty} (\hat{a}) = a$
  - **Unbiased** – *With finite statistics you get the right answer on average*
  - **Efficient**  $V(\hat{a}) = \langle (\hat{a} - \langle \hat{a} \rangle)^2 \rangle$  ← This is called the **Minimum Variance Bound**
  - ***There are no perfect estimators for real-life problems***

# Math – The Likelihood estimator

- **Definition** of Likelihood

- given  $\mathbf{D}(\vec{\mathbf{x}})$  and  $\mathbf{F}(\vec{\mathbf{x}}; \vec{\mathbf{p}})$

**Functions used in likelihoods must be Probability Density Functions:**

$$\int F(\vec{x}; \vec{p}) d\vec{x} \equiv 1, \quad F(\vec{x}; \vec{p}) > 0$$

$$L(\vec{p}) = \prod_i F(\vec{x}_i; \vec{p}), \quad \text{i.e.} \quad L(\vec{p}) = F(x_0; \vec{p}) \cdot F(x_1; \vec{p}) \cdot F(x_2; \vec{p}) \dots$$

- For convenience the *negative log of the Likelihood* is often used

$$-\ln L(\vec{p}) = -\sum_i \ln F(\vec{x}_i; \vec{p})$$

- Parameters are estimated by maximizing the Likelihood, or equivalently minimizing  $-\log(L)$

$$\left. \frac{d \ln L(\vec{p})}{d\vec{p}} \right|_{p_i = \hat{p}_i} = 0$$

# Math – Variance on ML parameter estimates

- **Estimator** for the **parameter variance** is

$$\hat{\sigma}(p)^2 = \hat{V}(p) = \left( \frac{d^2 \ln L}{d^2 p} \right)^{-1}$$

- I.e. variance is estimated from 2<sup>nd</sup> derivative of  $-\log(L)$  at minimum
- **Valid** if estimator is **efficient** and **unbiased!**

From Rao-Cramer-Frechet inequality

$$V(\hat{p}) \geq 1 + \frac{db}{dp} \left/ \left( \frac{d^2 \ln L}{d^2 p} \right) \right.$$

$b$  = bias as function of  $p$ , inequality becomes equality in limit of efficient estimator

- **Visual interpretation** of variance estimate

- Taylor expand  $-\log(L)$  around minimum

$$\begin{aligned} \ln L(p) &= \ln L(\hat{p}) + \left. \frac{d \ln L}{dp} \right|_{p=\hat{p}} (p - \hat{p}) + \frac{1}{2} \left. \frac{d^2 \ln L}{d^2 p} \right|_{p=\hat{p}} (p - \hat{p})^2 \\ &= \ln L_{\max} + \left. \frac{d^2 \ln L}{d^2 p} \right|_{p=\hat{p}} \frac{(p - \hat{p})^2}{2} \\ &= \ln L_{\max} + \frac{(p - \hat{p})^2}{2\hat{\sigma}_p^2} \Rightarrow \ln L(p \pm \sigma) = \ln L_{\max} - \frac{1}{2} \end{aligned}$$

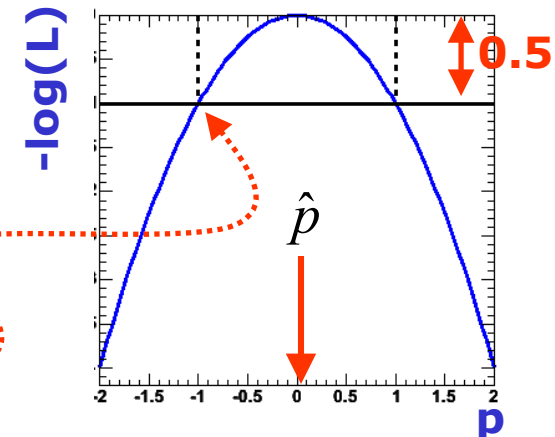

## Math – Properties of Maximum Likelihood estimators

---

- In general, Maximum Likelihood estimators are
  - **Consistent** (gives right answer for  $N \rightarrow \infty$ )
  - **Mostly unbiased** (bias  $\propto 1/N$ , may need to worry at small  $N$ )
  - **Efficient for large  $N$**  (you get the smallest possible error)
  - **Invariant:** (a transformation of parameters will Not change your answer, e.g.  $(\hat{p})^2 = \widehat{(p^2)}$ )

*Use of 2<sup>nd</sup> derivative of  $-\log(L)$   
for variance estimate is usually OK*

- MLE efficiency theorem: the MLE will be unbiased and efficient if an unbiased efficient estimator exists

# Math – Extended Maximum Likelihood

---

- Maximum likelihood information only parameterizes *shape* of distribution
  - I.e. one can determine *fraction* of signal events from ML fit, but not *number* of signal events

$$L(\vec{p}) = \prod_i F(\vec{x}_i; \vec{p}), \quad \text{i.e.} \quad L(\vec{p}) = F(x_0; \vec{p}) \cdot F(x_1; \vec{p}) \cdot F(x_2; \vec{p}) \dots$$

- Extended Maximum likelihood add extra term

$$-\log(L(\vec{p})) = -\sum_D \log(g(\vec{x}_i, \vec{p})) + \boxed{N_{\text{exp}} - N_{\text{obs}} \log(N_{\text{exp}})}$$

*Log of Poisson( $N_{\text{exp}}, N_{\text{obs}}$ )  
(modulo a constant)*

- Clever choice of parameters will allows us to extract  $N_{\text{sig}}$  and  $N_{\text{bkg}}$  in one pass (  $N_{\text{exp}} = N_{\text{sig}} + N_{\text{bkg}}$ ,  $f_{\text{sig}} = N_{\text{sig}} / (N_{\text{sig}} + N_{\text{bkg}})$  )

# RooFit core design philosophy

---

- Mathematical objects are represented as C++ objects

Mathematical concept

RooFit class

variable

$x$

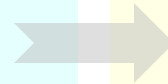

`RooRealVar`

function

$f(x)$

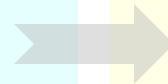

`RooAbsReal`

PDF

$f(x)$

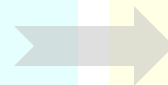

`RooAbsPdf`

space point

$\vec{x}$

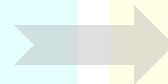

`RooArgSet`

integral

$\int_{x_{\min}}^{x_{\max}} f(x) dx$

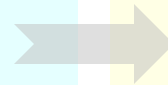

`RooRealIntegral`

list of space points

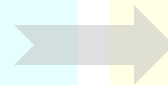

`RooAbsData`

# RooFit core design philosophy

---

- Represent relations between variables and functions as client/server links between objects

Math

$$f(x,y,z)$$

RooFit diagram

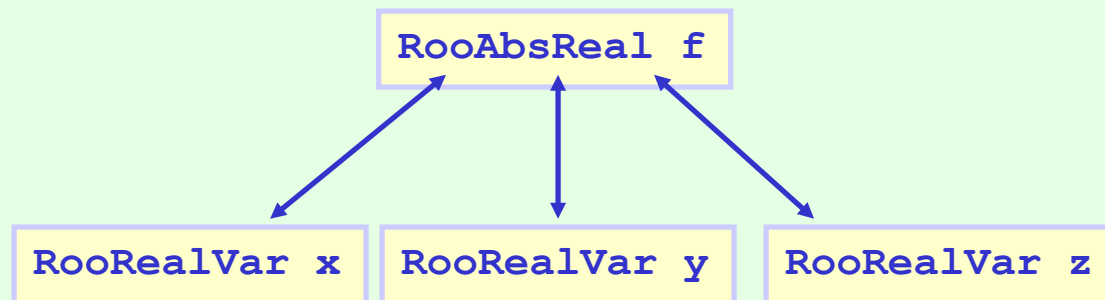

RooFit code

```
RooRealVar x("x","x",5) ;  
RooRealVar y("y","y",5) ;  
RooRealVar z("z","z",5) ;  
RooBogusFunction f("f","f",x,y,z) ;
```



# RooFit core design philosophy

- Composite functions → Composite objects

Math

$$f(w,z) \quad g(x,y) \quad \longrightarrow \quad f(g(x,y),z) = f(x,y,z)$$

RooFit diagram

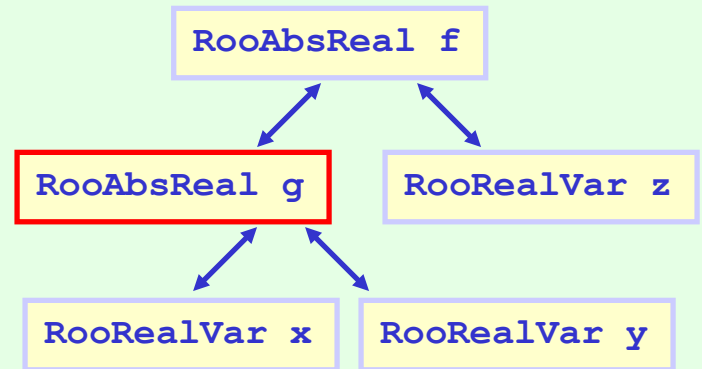
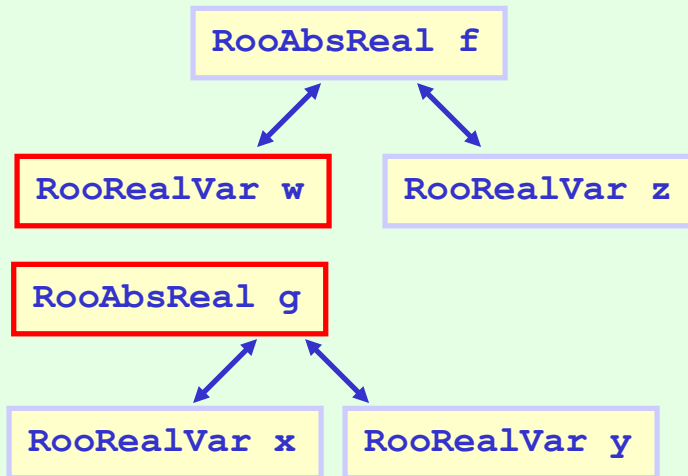

RooFit code

```

RooRealVar x("x","x",2) ;
RooRealVar y("y","y",3) ;
RooGooFunc g("g","g",x,y) ;

RooRealVar w("w","w",0) ;
RooRealVar z("z","z",5) ;
RooFooFunc f("f","f",w,z) ;
  
```

```

RooRealVar x("x","x",2) ;
RooRealVar y("y","y",3) ;
RooGooFunc g("g","g",x,y) ;

RooRealVar z("z","z",5) ;
RooFooFunc f("f","f",g,z) ;
  
```

# RooFit core design philosophy

- Represent integral as an object, instead of representing integration as an action

Math

$$g(x, m, s)$$

$$\longrightarrow \int_{x_{\min}}^{x_{\max}} g(x, m, s) dx = G(m, s, x_{\min}, x_{\max})$$

RooFit diagram

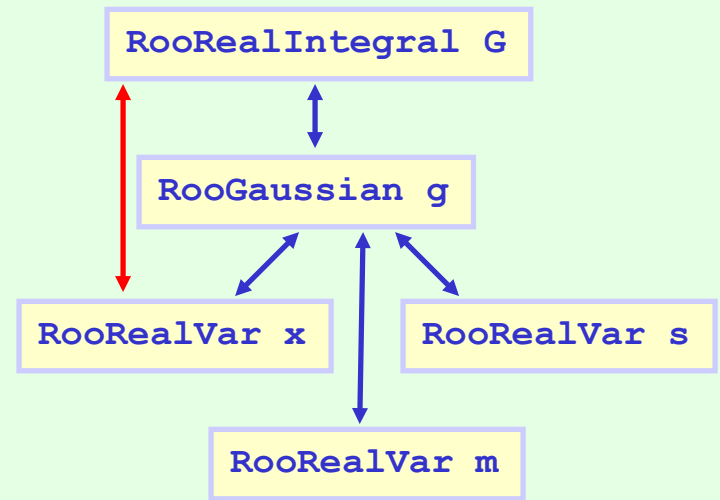
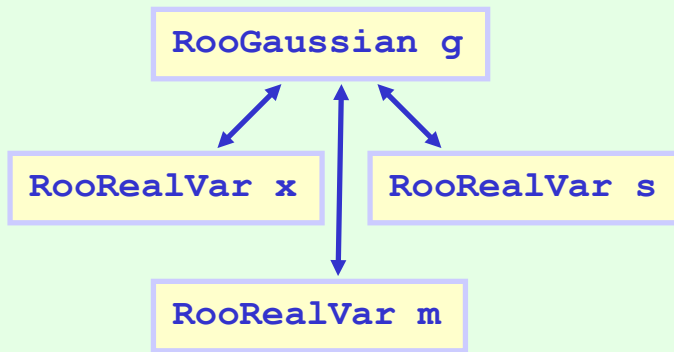

RooFit code

```

RooRealVar x("x","x",2,-10,10)
RooRealVar s("s","s",3) ;
RooRealVar m("m","m",0) ;
RooGaussian g("g","g",x,m,s)
  
```

```

RooAbsReal *G =
  g.createIntegral(x) ;
  
```

# Object-oriented data modeling

- In RooFit every variable, data point, function, PDF represented in a C++ object
  - Objects classified by data/function type they represent, not by their role in a particular setup
  - All objects are **self documenting**
    - **Name** - Unique identifier of object
    - **Title** - More elaborate description of object

Objects representing a 'real' value.

```
RooRealVar mass ("mass", "Invariant mass", 5.20, 5.30) ;  
RooRealVar width ("width", "B0 mass width", 0.00027, "GeV") ;  
RooRealVar mb0 ("mb0", "B0 mass", 5.2794, "GeV") ;
```

PDF object

```
RooGaussian b0sig ("b0sig", "B0 sig PDF", mass, mb0, width) ;
```

Initial range

Initial value Optional unit

References to variables

# RooFit designed goals for easy-of-use in macros

- Mathematical concepts mimicked as much as possible in class design
  - Intuitive to use
- **Every object** that can be constructed through composition should be **fully functional**
  - No implementation level restrictions
  - No zombie objects
- **All methods must work on all objects**
  - Integration, toyMC generation, etc
  - No half-working classes

# 2 Basic Functionality

- *Creating a p.d.f*
- *Basic fitting, plotting, event generation*
- *Some details on normalization, event generation*
- *Library of basic shapes (including non-parametric shapes)*

# Basics – Creating and plotting a Gaussian p.d.f

Setup gaussian PDF and plot

```
// Build Gaussian PDF
RooRealVar x("x","x",-10,10) ;
RooRealVar mean("mean","mean of gaussian",0,-10,10) ;
RooRealVar sigma("sigma","width of gaussian",3) ;

RooGaussian gauss("gauss","gaussian PDF",x,mean,sigma) ;

// Plot PDF
RooPlot* xframe = x.frame()
gauss.plotOn(xframe) ;
xframe->Draw() ;
```

Axis label from gauss title

A RooPlot is an empty frame capable of holding anything plotted versus its variable

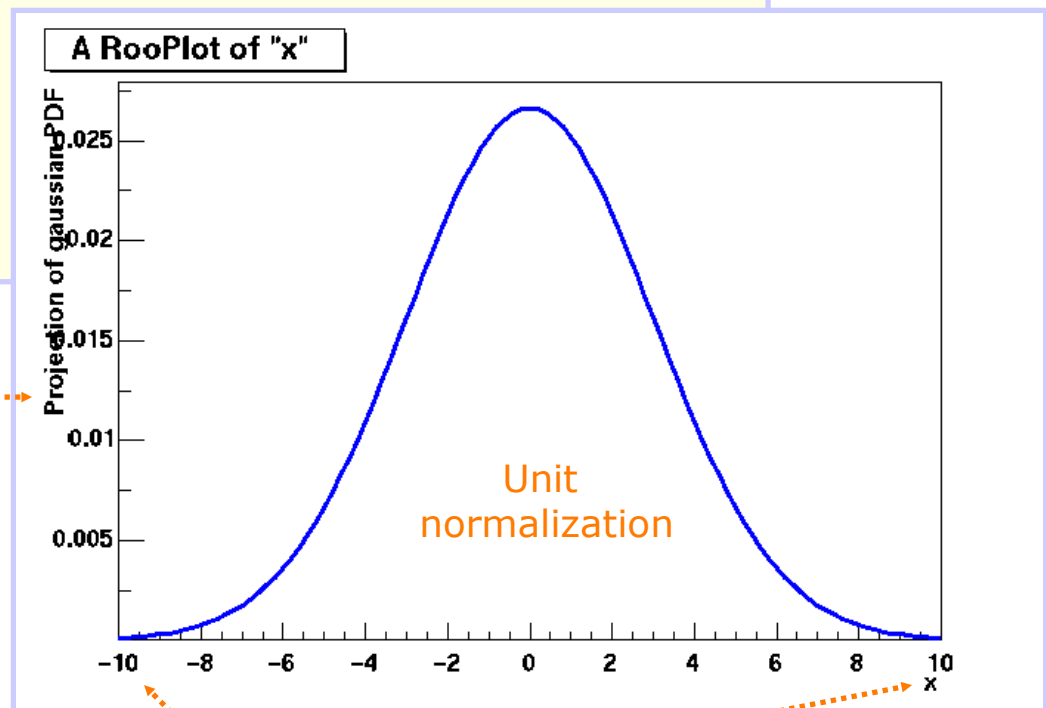

Plot range taken from limits of x

# Basics – Generating toy MC events

Generate 10000 events from Gaussian p.d.f and show distribution

```
// Generate a toy MC set
RooDataSet* data = gauss.generate(x,10000) ;

// Plot PDF
RooPlot* xframe = x.frame() ;
data->plotOn(xframe) ;
xframe->Draw() ;
```

Returned dataset is **unbinned** dataset (like a ROOT TTree with a RooRealVar as branch buffer)

Binning into histogram is performed in `data->plotOn()` call

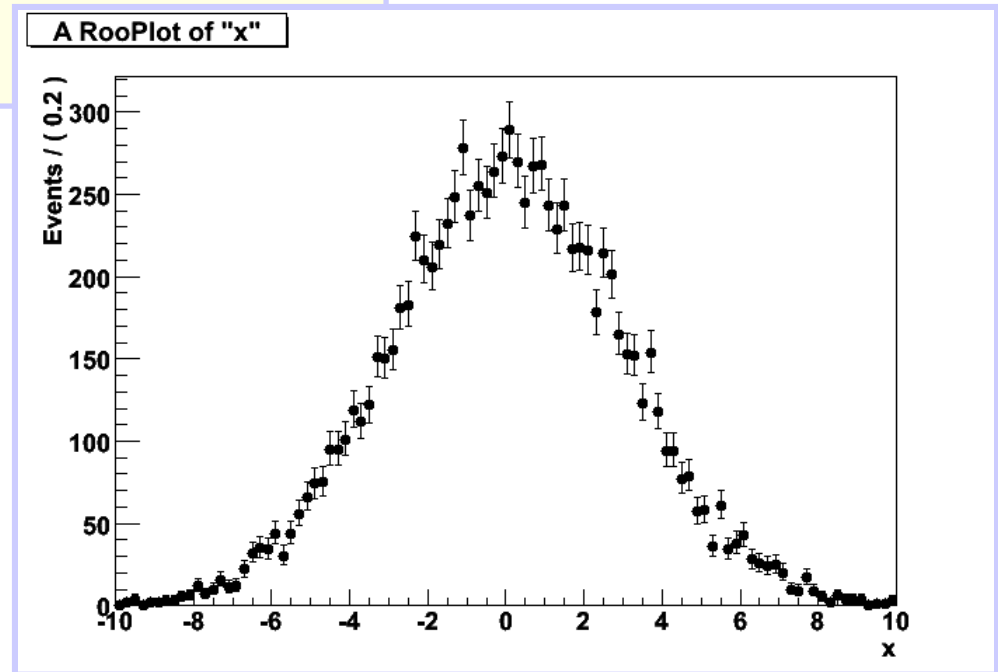

# Basics – ML fit of p.d.f to *unbinned* data

demo1.cc

```
// ML fit of gauss to data
gauss.fitTo(*data) ;
(MINUIT printout omitted)

// Parameters if gauss now
// reflect fitted values
mean.Print()
RooRealVar::mean = 0.0172335 +/- 0.0299542
sigma.Print()
RooRealVar::sigma = 2.98094 +/- 0.0217306

// Plot fitted PDF and toy data overlaid
RooPlot* xframe2 = x.frame() ;
data->plotOn(xframe2) ;
gauss.plotOn(xframe2) ;
xframe2->Draw() ;
```

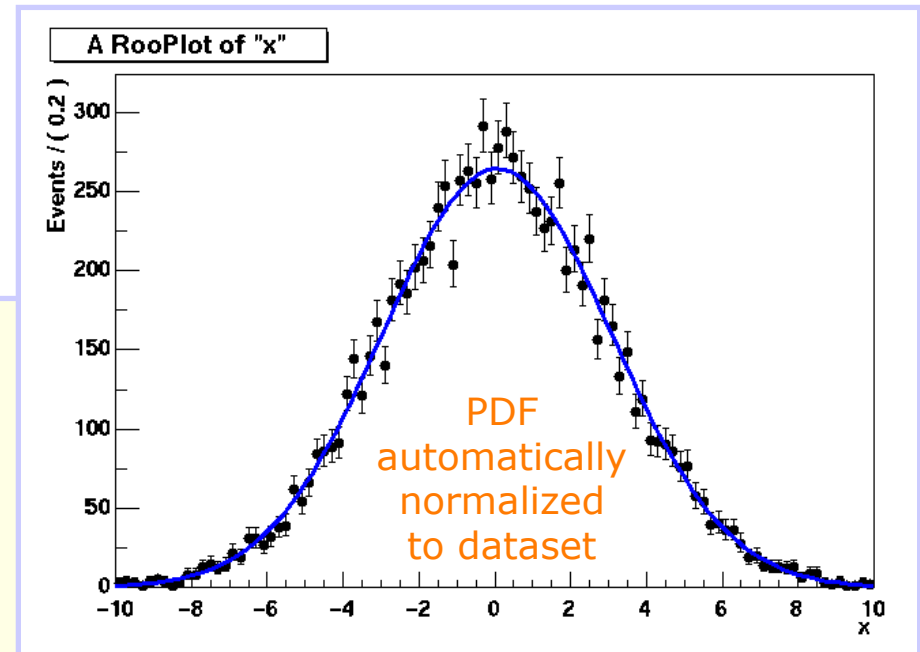



# Basics – RooPlot Decoration

- A RooPlot is an empty frame that can contain
  - RooDataSet projections
  - PDF and generic real-valued function projections
  - Any ROOT drawable object (arrows, text boxes etc)
- Adding a dataset statistics box / PDF parameter box

```
RooPlot* frame = x.frame() ;  
data.plotOn(xframe) ;  
pdf.plotOn(xframe) ;  
pdf.paramOn(xframe, data) ;  
data.statOn(xframe) ;  
xframe->Draw() ;
```

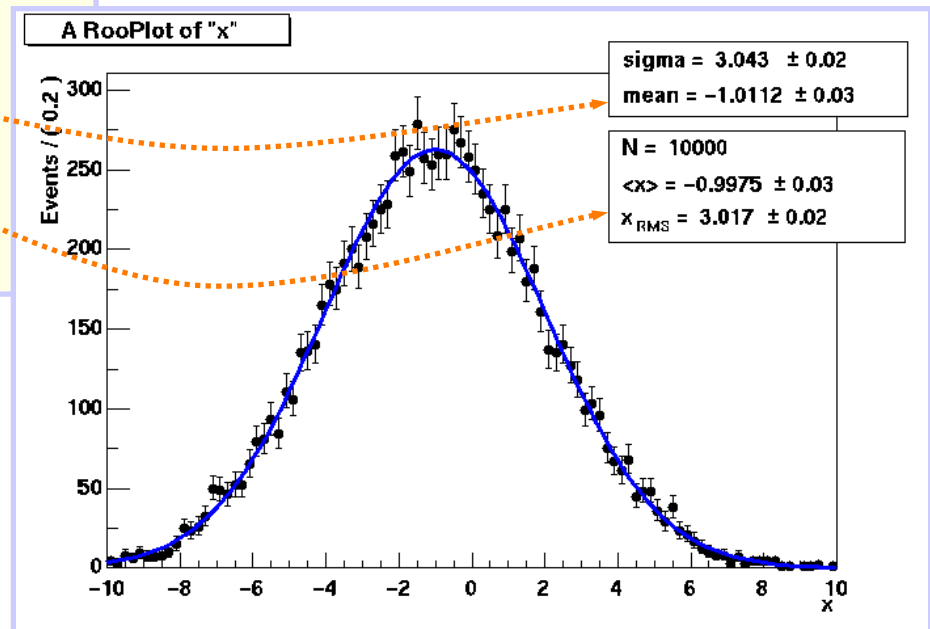

# Basics – RooPlot decoration

- Adding generic ROOT text boxes, arrows etc.

```
TPaveText* tbox = new TPaveText(0.3,0.1,0.6,0.2,"BRNDC");  
tbox->AddText("This is a generic text box");  
TArrow* arr = new TArrow(0,40,3,100);  
  
xframe2->addObject(arr);  
xframe2->addObject(tbox);
```

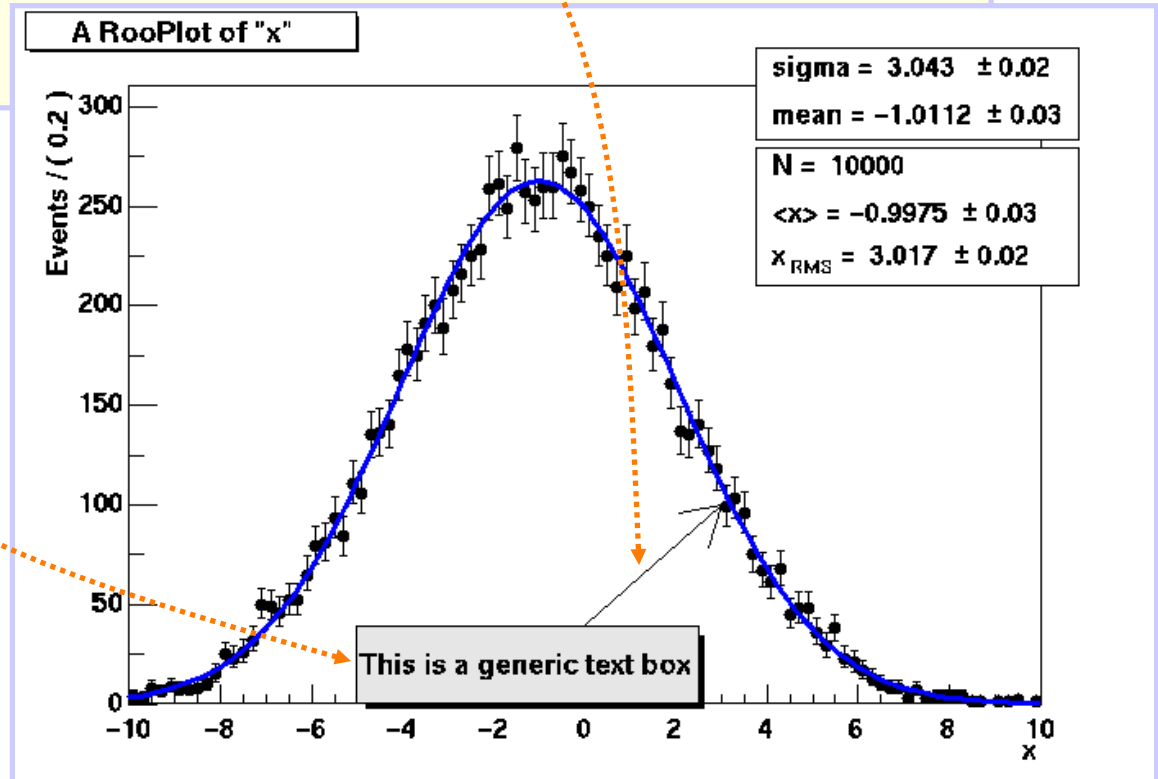

***You can save a RooPlot  
with all its decorations  
in a ROOT file***

## Basics – Observables and parameters of Gauss

---

- Class `RooGaussian` has *no intrinsic notion* of distinction between observables and parameters
- Distinction always implicit in use context with dataset
  - **x** = observable (as it is a variable in the dataset)
  - **mean, sigma** = parameters
- Choice of observables (for unit normalization) always passed to `gauss.getVal()`

```
gauss.getVal() ; // Not normalized (i.e. this is not a pdf)
gauss.getVal(x) ; // Guarantees Int[xmin, xmax] Gauss(x, m, s) dx == 1
gauss.getVal(s) ; // Guarantees Int[smin, smax] Gauss(x, m, s) ds == 1
```

## How does it work – Normalization

---

- Flexible choice of normalization facilitated by explicit normalization step in RooFit p.d.f.s

`gauss.getVal(x)`

$$g(\mathbf{x}; m, s) = \frac{g(x, m, s)}{\int_{x_{\min}}^{x_{\max}} g(x, m, s) dx}$$

`gauss.getVal(s)`

$$g(\mathbf{s}; m, x) = \frac{g(x, m, s)}{\int_{s_{\min}}^{s_{\max}} g(x, m, s) ds}$$

- Supporting class `RooRealIntegral` responsible for calculation of any

$$\int_{\vec{x}_{\min}}^{\vec{x}_{\max}} g(\vec{x}; \vec{p}) d\vec{x}$$

- Negotiation with p.d.f on which (partial) integrals it can internally perform analytically
- Missing parts are supplemented with numerical integration
- Class `RooRealIntegral` can in principle integrate *everything*.

# How does it work – Normalization

- A peak in the code of class `RooGaussian`

```
// Raw (unnormalized value) of Gaussian
Double_t RooGaussian::evaluate() const {
    Double_t arg= x - mean;
    return exp(-0.5*arg*arg/(sigma*sigma)) ;
}

// Advertise that x can be integrated internally
Int_t RooGaussian::getAnalyticalIntegral(RooArgSet& allVars,
    RooArgSet& analVars, const char* /*rangeName*/) const {
    if (matchArgs(allVars,analVars,x)) return 1 ;
    return 0 ;
}

// Implementation of analytical integral over x
Double_t RooGaussian::analyticalIntegral(Int_t code,
    const char* rname) const {
    static const Double_t root2 = sqrt(2.) ;
    static const Double_t rootPiBy2 = sqrt(atan2(0.0,-1.0)/2.0) ;
    Double_t xscale = root2*sigma;
    return rootPiBy2*sigma*(RooMath::erf((x.max(rname)-mean)/xscale)
        -RooMath::erf((x.min(rname)-mean)/xscale)) ;
}
```

# Basics – Integrals over p.d.f.s

- It is easy to create an object representing integral over a normalized p.d.f in a sub-range

```
x.setRange("sig",-3,7) ;  
RooAbsReal* ig = g.createIntegral(x, NormSet(x), Range("sig")) ;  
cout << ig.getVal() ;  
0.832519  
mean=-1  
cout << ig.getVal() ;  
0.743677
```

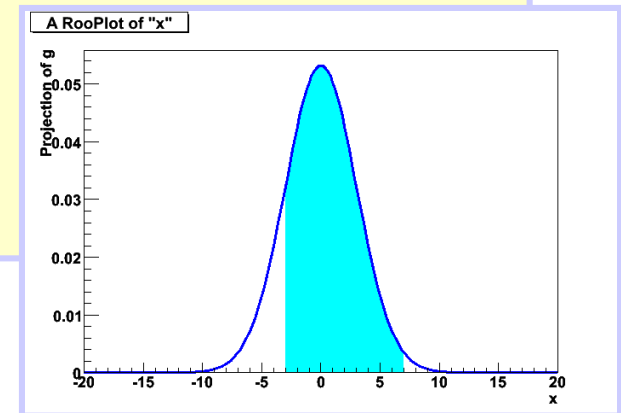

- Similarly, one can also request the *cumulative distribution function*

$$C(x) = \int_{x_{\min}}^x F(x') dx'$$

```
RooAbsReal* cdf = gauss.createCdf(x) ;  
RooPlot* frame = x.frame() ;  
cdf->plotOn(frame) ->Draw() ;
```

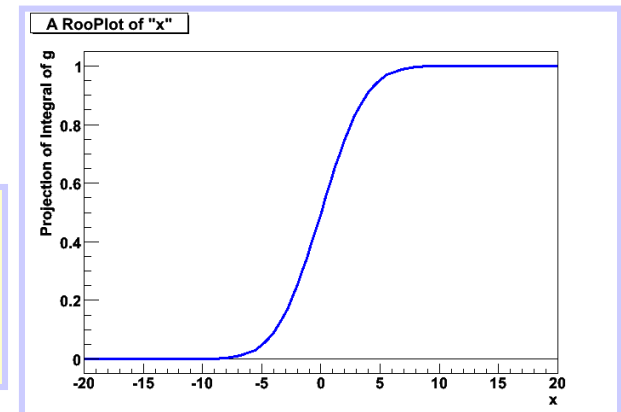

# How does it work – toy event generation

- By default RooFit implements an accept/reject sampling technique to generate toy events from a p.d.f.

- Determine maximum of function  $f_{\max}$
- Throw random number  $x$
- Throw another random number  $y$
- If  $y < f(x)/f_{\max}$  keep  $x$ , otherwise return to step 2)

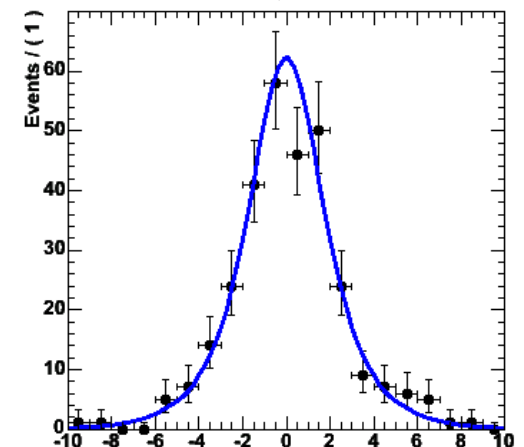
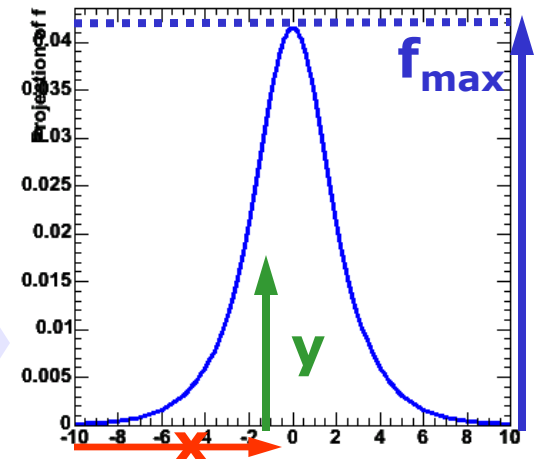

# How does it work – toy event generation

- Accept/reject method can be very inefficient

– Generating efficiency is

$$\frac{\int_{x_{\max}}^{x_{\min}} f(x) dx}{(x_{\max} - x_{\min}) \cdot f_{\max}}$$

- Efficiency is very low for narrowly peaked functions
- Initial sampling for  $f_{\max}$  requires very large trials sets in multiple dimension ( $\sim 10000000$  in 3D)

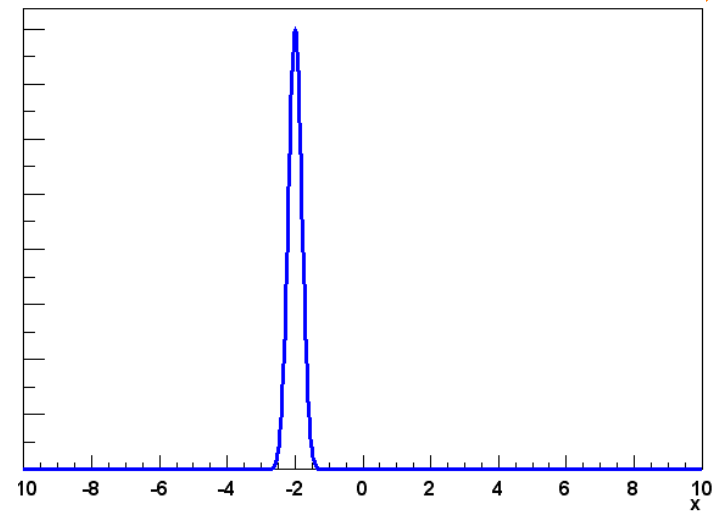
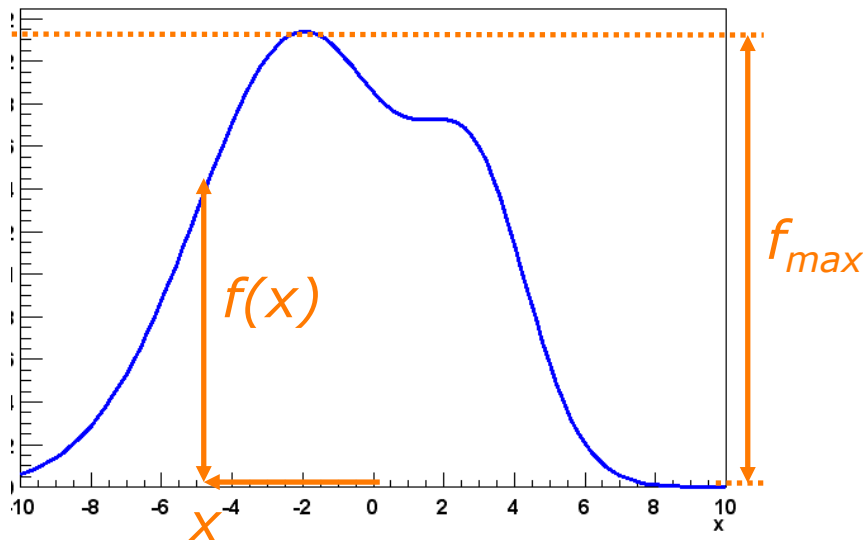



# Toy MC generation – Inversion method

- Analoguous to integration, p.d.f can ad generator in case it can be done with a technique
- E.g. function inversion

1) Given  $f(x)$  find inverted function  $F(x)$   
so that  $f( F(x) ) = x$

2) Throw uniform random number  $x$

3) Return  $F(x)$

- Maximally efficient, but only works for class of p.d.f.s that is invertible

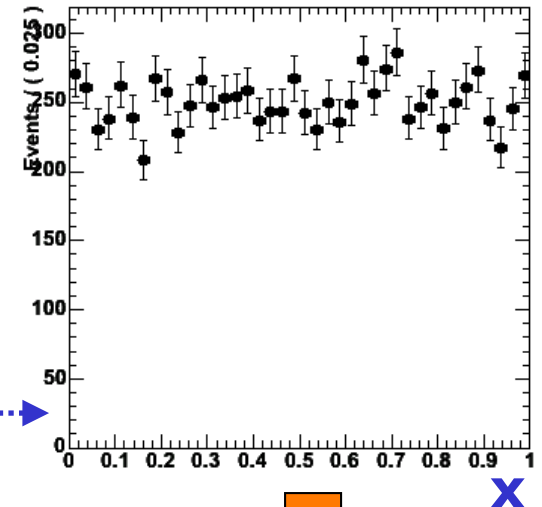

Take  $-\log(x)$

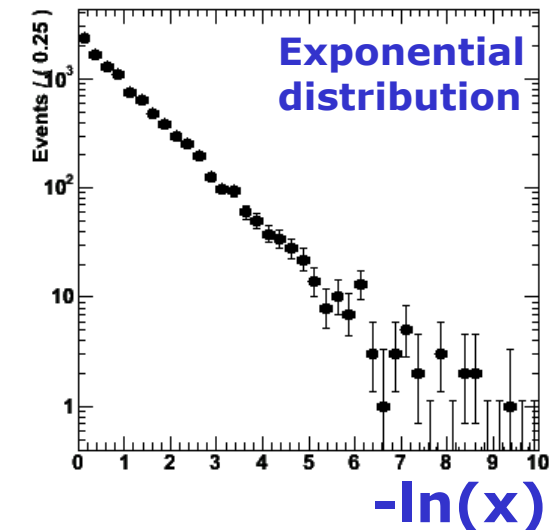

# Toy MC generation – hybrid method

- Hybrid technique of importance sampling applicable to larger class of p.d.f.s

- 1) Find 'envelope function'  $g(x)$  that is invertible into  $G(x)$  and that fulfills  $g(x) \geq f(x)$  for all  $x$
- 2) Generate random number  $x$  from  $G$  using inversion method
- 3) Throw random number ' $y$ '
- 4) If  $y < f(x)/g(x)$  keep  $x$ , otherwise return to step 2

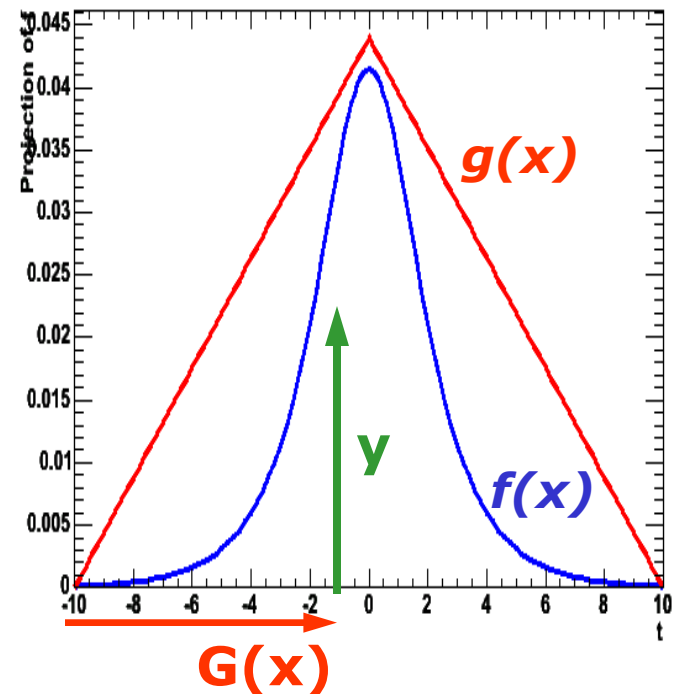

- PRO: Faster than plain accept/reject sampling  
Function does not need to be invertible
- CON: Must be able to find invertible envelope function

# Toy MC generation – A peek inside RooBMixDecay

```
void RooBMixDecay::generateEvent(Int_t code) {
  while(1) {
    // Exponential decay envelope function through inversion
    Double_t rand = RooRandom::uniform() ;
    Double_t tval = -_tau*log(rand);

    // Importance sampling of envelope
    Double_t dil = 1-2.*mistag ;
    Double_t maxAcceptProb = 1 + TMath::Abs(delMistag) + TMath::Abs(dil) ;
    Double_t acceptProb = (1-tagFlav*delMistag) + _mixState*dil*cos(dm*tval);
    Bool_t mixAccept = maxAcceptProb*RooRandom::uniform() < acceptProb ? kTRUE : kFALSE ;

    // Accept event if t is in generated range
    if (tval<_t.max() && tval>_t.min() && mixAccept) {
      _t = tval ;
      break ;
    }
  }
}
```

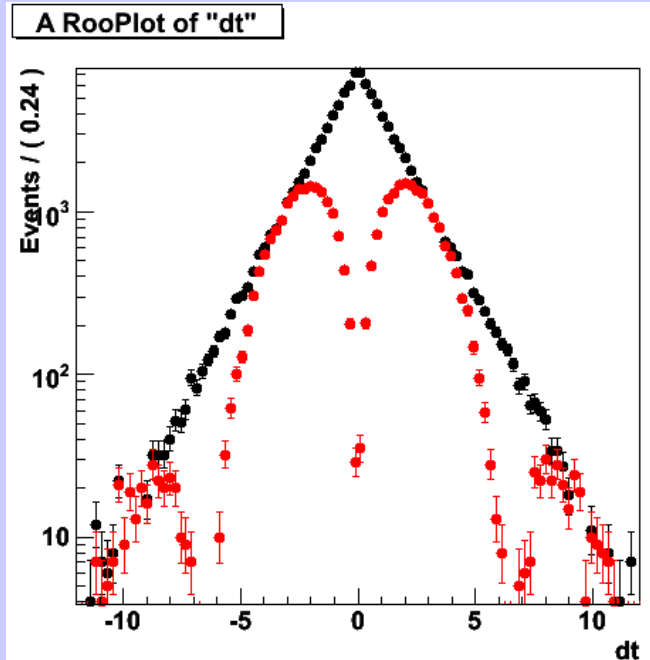

# Model building – (Re)using standard components

- RooFit provides a collection of compiled standard PDF classes

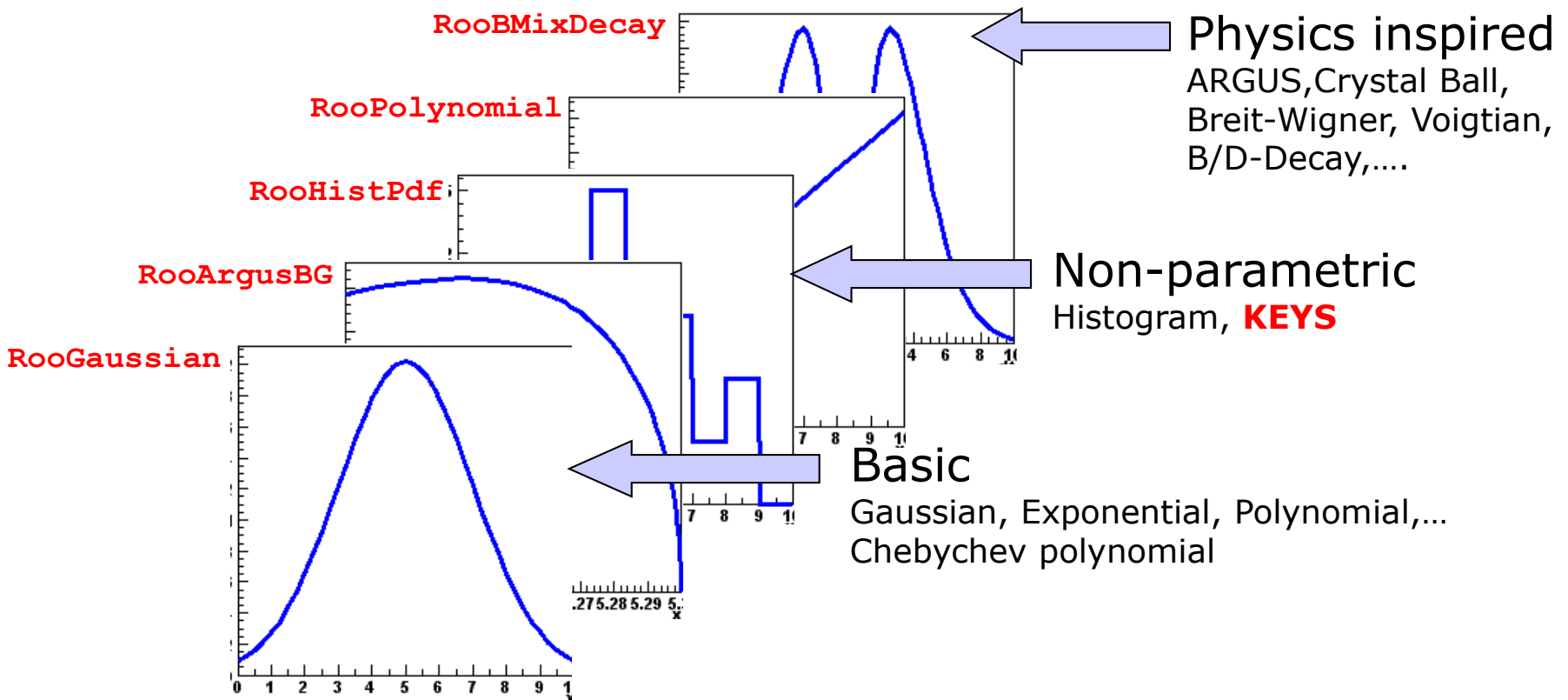

*Easy to extend the library: each p.d.f. is a separate C++ class*

# Model building – Generic expression-based PDFs

- If your favorite PDF isn't there and you don't want to code a PDF class right away  
→ **USE RooGenericPdf**
- Just write down the PDFs expression as a C++ formula

```
// PDF variables
RooRealVar x("x","x",-10,10) ;
RooRealVar y("y","y",0,5) ;
RooRealVar a("a","a",3.0) ;
RooRealVar b("b","b",-2.0) ;

// Generic PDF
RooGenericPdf gp("gp","Generic PDF","exp(x*y+a) -b*x",
                 RooArgSet(x,y,a,b)) ;
```

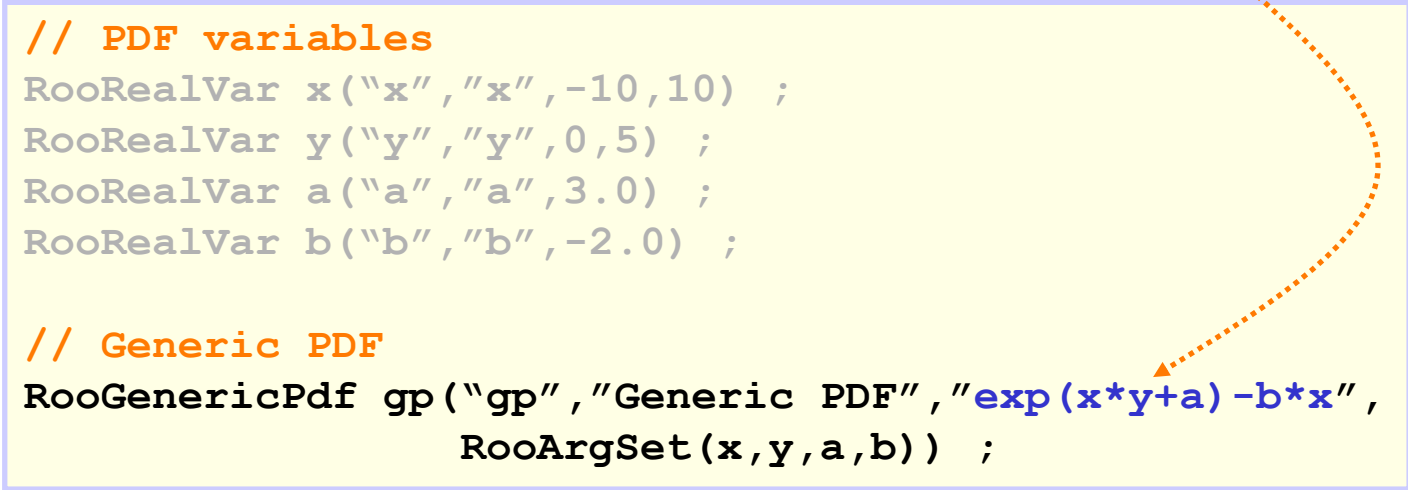

- Numeric normalization automatically provided

# Model Building – Writing your own class

---

- Factory class exists (**RooClassFactory**) that can write, compile, link C++ code for RooFit p.d.f. and function classes
- **Example 1:**
  - Write class **MyPdf** with variable x,y,a,b in files **MyPdf.h**, **MyPdf.cxx**

```
RooClassFactory::makePdf("MyPdf", "x,y,a,b");
```

- Only need to fill **evaluate()** method in **MyPdf.cxx** in terms of a,b,x
- Can add optional code to support for analytical integration, internal event generation

# Model Building – Writing your own class

---

- **Example 2:**

- Functional equivalent to `RooGenericPdf`: Write class `MyPdf` with prefilled one-line function expression, compile and link p.d.f, create and return instance of class

### *Compiled code*

```
RooAbsPdf* gp = RooClassFactory::makePdfInstance("gp",  
"exp(x*y+a)-b*x", RooArgSet(x,y,a,b));
```

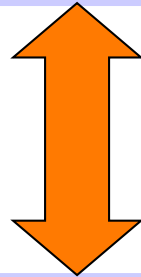

### *Interpreted code*

```
RooGenericPdf gp("gp", "Generic PDF", "exp(x*y+a)-b*x",  
RooArgSet(x,y,a,b));
```

# Highlight of non-parametric shapes - histograms

- Will highlight two types of non-parametric p.d.f.s
- Class `RooHistPdf` – a p.d.f. described by a histogram

`dataHist`

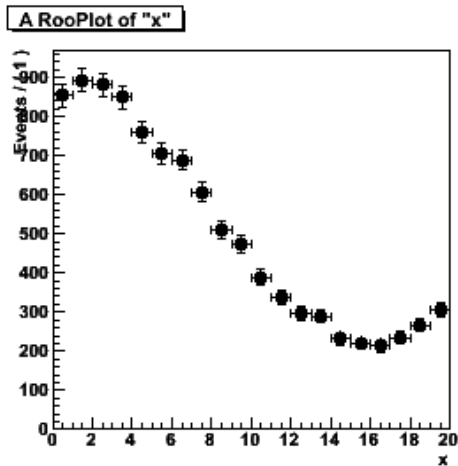

`RooHistPdf (N=0)`

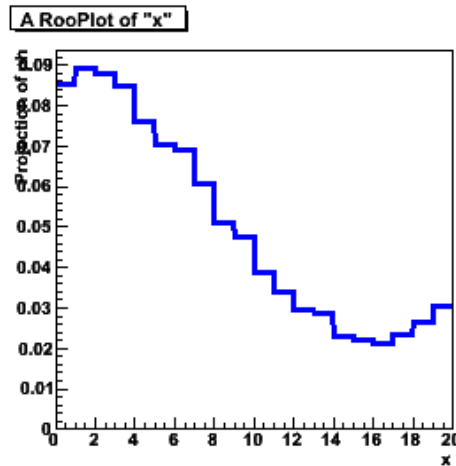

`RooHistPdf (N=4)`

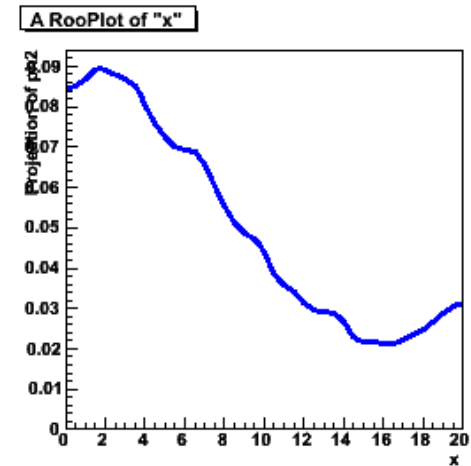

```
// Histogram based p.d.f with N-th order interpolation  
RooHistPdf ph("ph", "ph", x, *dataHist, N) ;
```

- Not so great at low statistics (especially problematic in  $>1$  dim)



# Highlight of non-parametric shapes – kernel estimation

- Class `RooKeysPdf` – A kernel estimation p.d.f.
  - Uses *unbinned* data
  - Idea represent each event of your MC sample as a Gaussian probability distribution
  - Add probability distributions from all events in sample

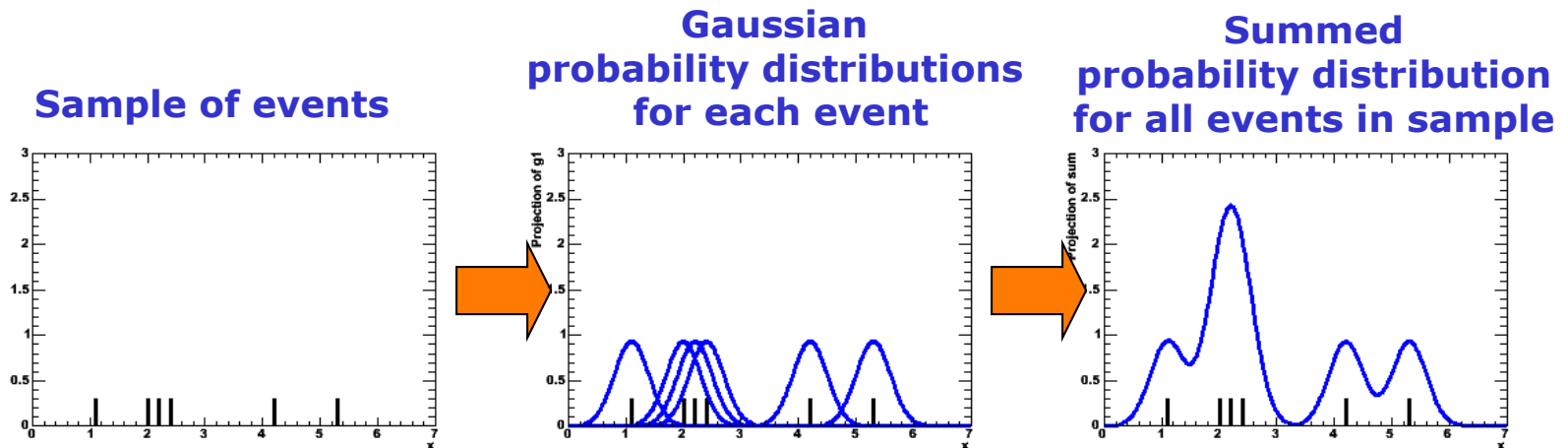

# Highlight of non-parametric shapes – kernel estimation

- Width of Gaussian kernels need not be the same for all events
  - As long as each event contributes  $1/N$  to the integral
- Idea: 'Adaptive kernel' technique
  - Choose wide Gaussian if local density of events is low
  - Choose narrow Gaussian if local density of events is high
  - Preserves small features in high statistics areas, minimize jitter in low statistics areas
  - Automatically calculated

**Static Kernel**  
(with of all Gaussian identical)

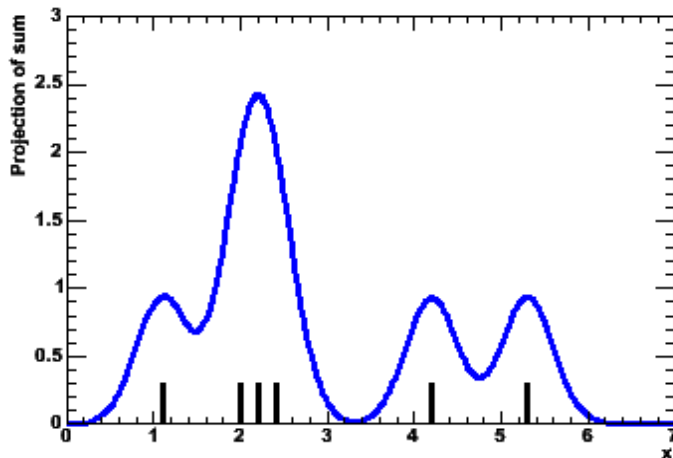

**Adaptive Kernel**  
(width of all Gaussian depends on local density of events)

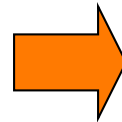
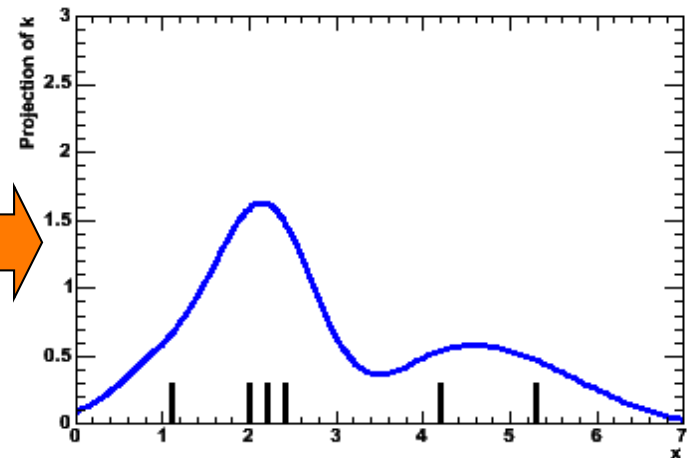

# Highlight of non-parametric shapes – kernel estimation

- Example with comparison to histogram based p.d.f
  - Superior performance at low statistics
  - Can mirror input data over boundaries to reduce 'edge leakage'
  - Works also in  $>1$  dimensions (class `RooNDKeysPdf`)

```
// Adaptive kernel estimation p.d.f  
RooKeysPdf k("k", "k", x, *d, RooKeysPdf::MirrorBoth) ;
```

Data (N=500)

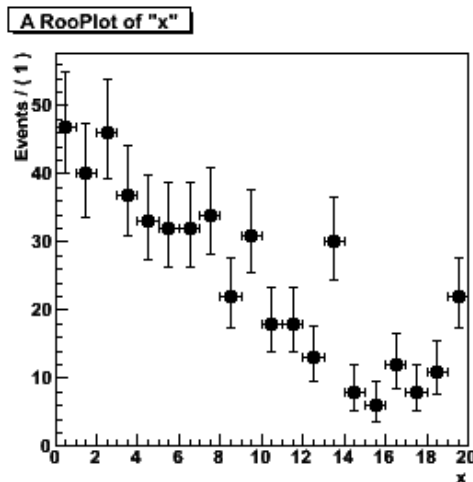

RooHistPdf (data)

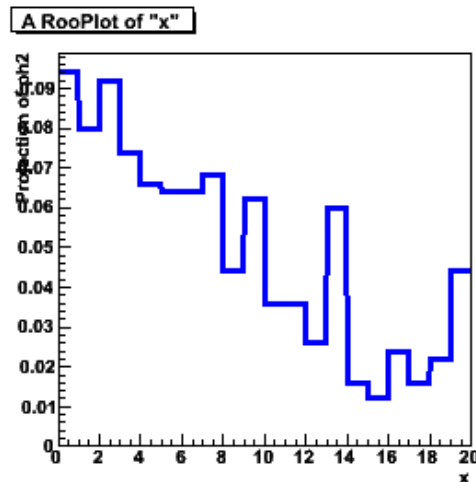

RooKeysPdf (data)

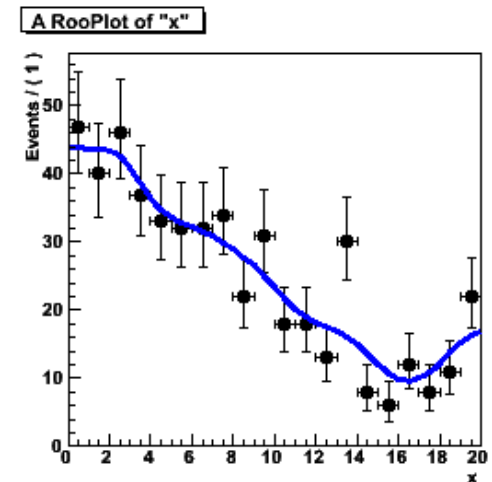

# 3 P.d.f. addition & convolution

- *Using the addition operator p.d.f*
- *Using the convolution operator p.d.f.*

# Building realistic models

- Complex PDFs can be trivially composed using operator classes

## - Addition

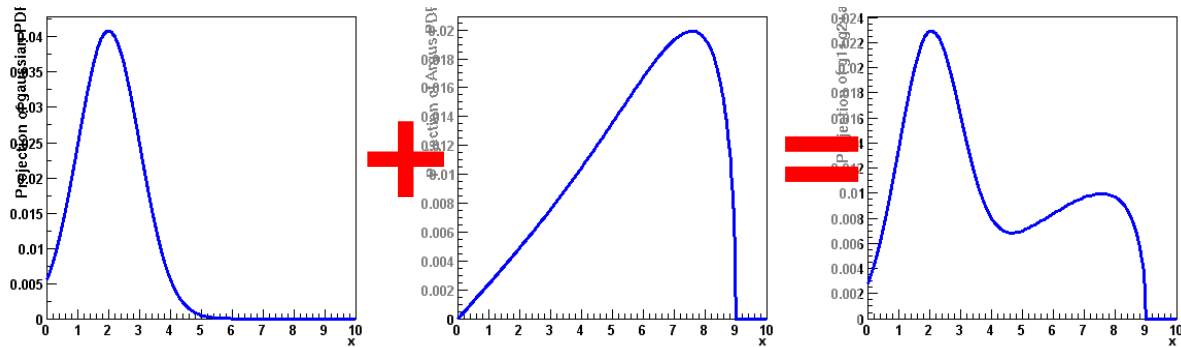

## - Convolution

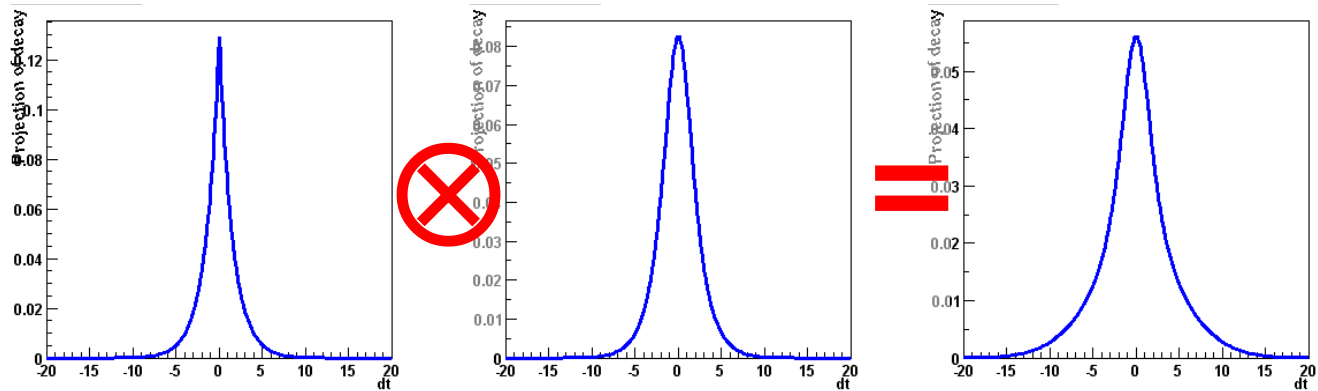

# Model building – (Re)using standard components

- Most realistic models are constructed as the sum of one or more p.d.f.s (e.g. signal and background)
- Facilitated through **operator p.d.f RooAddPdf**

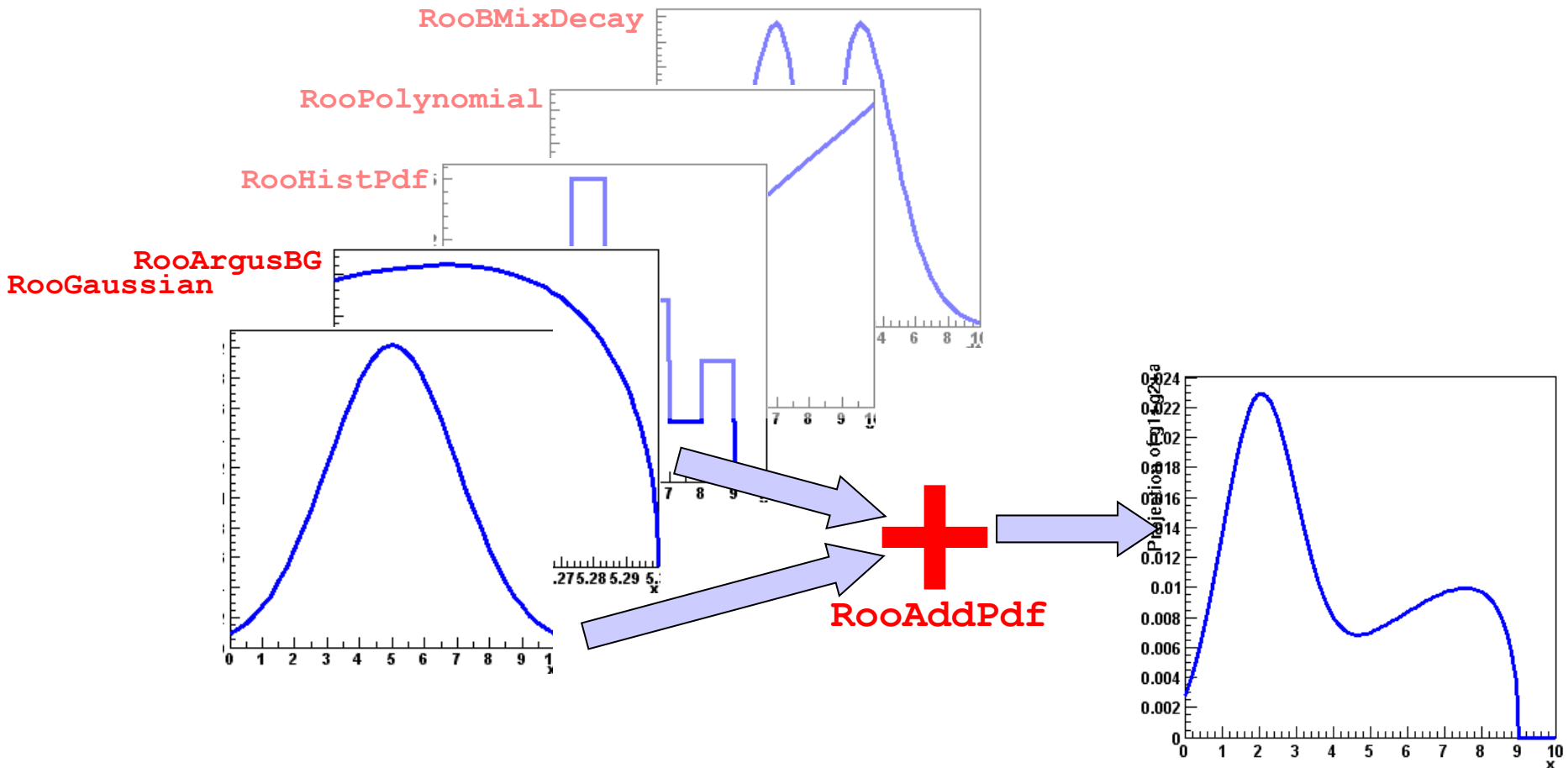

## Adding p.d.f.s – Mathematical side

---

- From math point of view adding p.d.f is simple

- Two components  $F, G$

$$S(x) = fF(x) + (1-f)G(x)$$

- Generically for  $N$  components  $P_0-P_N$

$$S(x) = c_0P_0(x) + c_1P_1(x) + \dots + c_{n-1}P_{n-1}(x) + \left(1 - \sum_{i=0, n-1} c_i\right)P_n(x)$$

- For  $N$  p.d.f.s, there are  $N-1$  fraction coefficients that should sum to less 1
  - The remainder is by construction 1 minus the sum of all other coefficients

# Constructing a sum of p.d.f.s

`RooAddPdf` constructs the sum of N PDFs with N-1 coefficients:

$$S = c_0 P_0 + c_1 P_1 + c_2 P_2 + \dots + c_{n-1} P_{n-1} + \left(1 - \sum_{i=0, n-1} c_i\right) P_n$$

Build 2  
Gaussian  
PDFs

```
// Build two Gaussian PDFs
```

```
RooRealVar x("x","x",0,10) ;  
RooRealVar mean1("mean1","mean of gaussian 1",2) ;  
RooRealVar mean2("mean2","mean of gaussian 2",3) ;  
RooRealVar sigma("sigma","width of gaussians",1) ;  
RooGaussian gauss1("gauss1","gaussian PDF",x,mean1,sigma) ;  
RooGaussian gauss2("gauss2","gaussian PDF",x,mean2,sigma) ;
```

Build  
ArgusBG  
PDF

```
// Build Argus background PDF
```

```
RooRealVar argpar("argpar","argus shape parameter",-1.0) ;  
RooRealVar cutoff("cutoff","argus cutoff",9.0) ;  
RooArgusBG argus("argus","Argus PDF",x,cutoff,argpar) ;
```

```
// Add the components
```

```
RooRealVar g1frac("g1frac","fraction of gauss1",0.5) ;  
RooRealVar g2frac("g2frac","fraction of gauss2",0.1) ;  
RooAddPdf sum("sum","g1+g2+a",RooArgList(gauss1,gauss2,argus),  
              RooArgList(g1frac,g2frac)) ;
```

v List of coefficients



# Plotting a sum of p.d.f.s, and its components

```
// Generate a toyMC sample
RooDataSet *data =
    sum.generate(x,10000) ;

// Plot data and PDF overlaid
RooPlot* xframe = x.frame() ;
data->plotOn(xframe) ;
sum->plotOn(xframe) ;

// Plot only argus and gauss2
sum->plotOn(xframe,Components(RooArgSet(argus,gauss2))) ;
xframe->Draw() ;
```

Plot selected  
components  
of a RooAddPdf

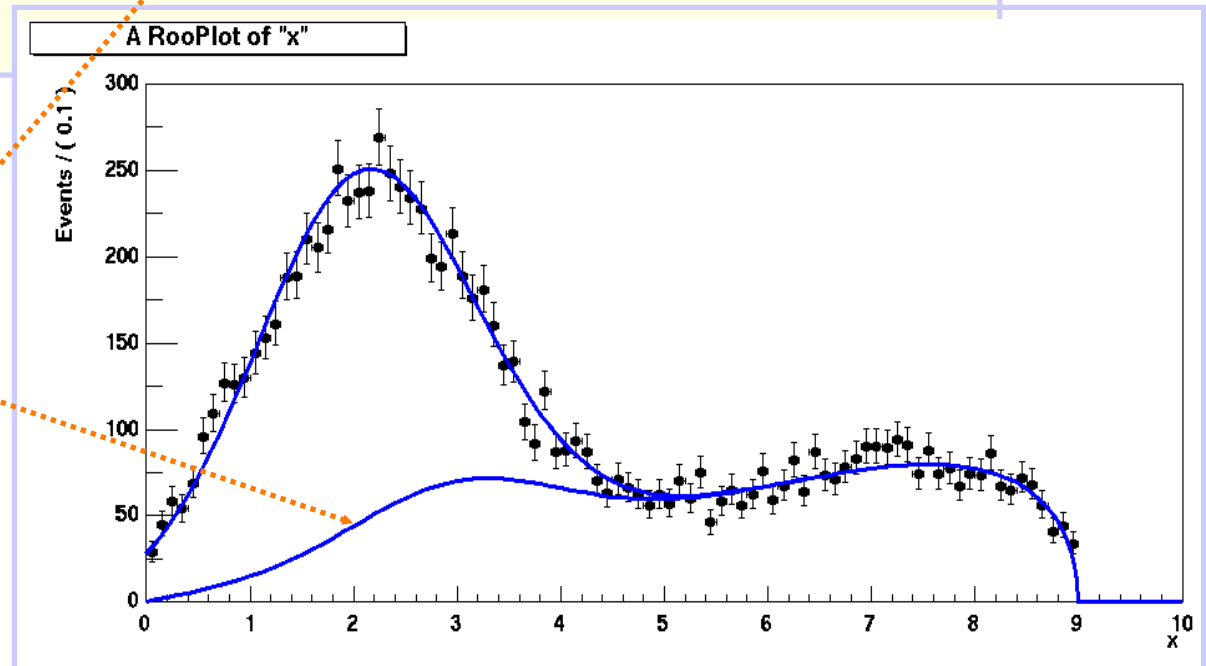

# Component plotting - Introduction

- Also special tools for plotting of components in RooPlots
  - Use Method `Components()`

- Example:  
Argus + Gaussian PDF

```
// Plot data and full PDF first  
// Now plot only argus component  
sum->plotOn(xframe,  
            Components(argus), LineStyle(kDashed)) ;
```

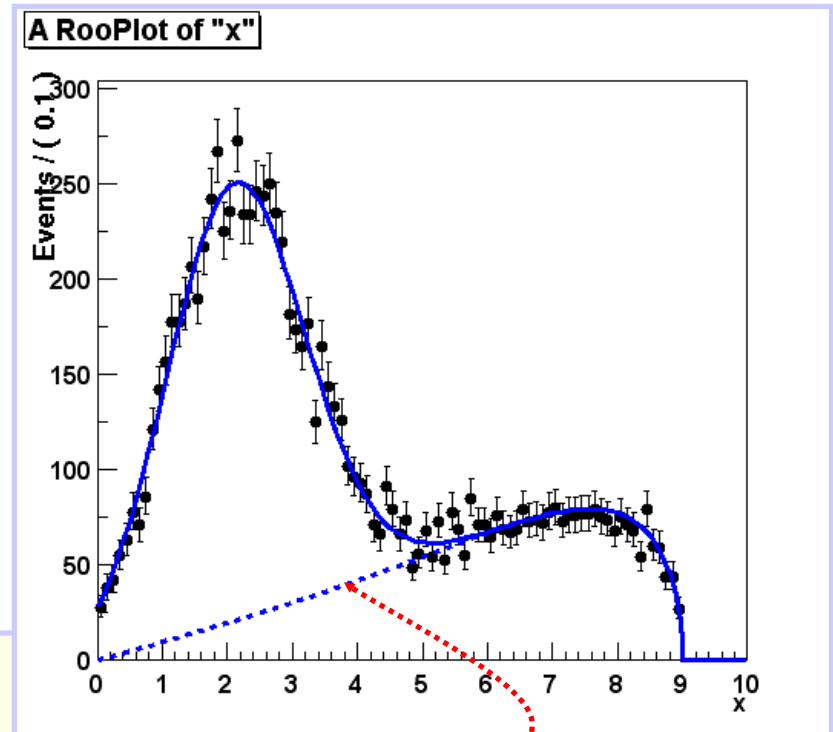

# Component plotting – Selecting components

---

There are various ways to select **single** or **multiple** components to plot

Can refer to components either by name or reference

```
// Single component selection
pdf->plotOn(frame, Components(argus)) ;
pdf->plotOn(frame, Components("gauss")) ;

// Multiple component selection
pdf->plotOn(frame, Components(RooArgSet(pdfA, pdfB))) ;
pdf->plotOn(frame, Components("pdfA, pdfB")) ;

// Wild card expression allowed
pdf->plotOn(frame, Components("bkgA*, bkgB*")) ;
```

# Recursive fraction form of RooAddPdf

- Fitting a sum of  $>2$  p.d.f.s can pose some problems as the sum of the coefficients  $f_1 \dots f_{N-1}$  may become  $>1$ 
  - This results in a **negative remainder component** ( $\equiv 1 - \sum f_i$ )
  - Composite p.d.f may still be positive definite, but interpretation less clear
  - Could set limits on fractions  $f_i$  to avoid  $\sum f_i > 1$  scenario, but where to put limits?
- Viable alternative to write as sum of **recursive** fractions

$$S_2(x) = f_1 P_1(x) + (1 - f_1) P_2(x)$$

$$S_3(x) = f_1 P_1(x) + (1 - f_1) (f_2 P_2(x) + (1 - f_2) P_3(x))$$

$$S_4(x) = f_1 P_1(x) + (1 - f_1) (f_2 P_2(x) + (1 - f_2) (f_3 P_3(x) + (1 - f_3) P_4(x)))$$

```
// Add the components with recursive fractions
```

```
RooAddPdf sum("sum", "fA*a+(fG*g1+g2)", RooArgList(a, g1, g2),  
              RooArgList(afrac, gfrac), kTRUE) ;
```

## Extended p.d.f form of RooAddPdf

---

- If extended ML term is introduced, we **can fit expected number of events ( $N_{exp}$ )** in addition to shape parameters
- In case of sum of p.d.f.s it is convenient to *re-parameterize* sum of p.d.f.s.

$$\begin{pmatrix} f_{sig} \\ N_{exp} \end{pmatrix} \Rightarrow \begin{pmatrix} N_{sig} \equiv f_{sig} N_{exp} \\ N_{bkg} \equiv (1 - f_{sig}) N_{exp} \end{pmatrix}$$

- This transformation is applied automatically in **RooAddPdf** if equal number of p.d.f.s and coefs are given

```
RooRealVar nsig("nsig","number of signal events",100,0,10000) ;  
RooRealVar nbkg("nbkg","number of backgnd events",100,0,10000) ;  
RooAddPdf sume("sume","extended sum pdf",RooArgList(gauss, argus) ,  
              RooArgList(nsig,nbkg)) ;
```

# General features of extended p.d.f.s

---

- Extended term  $-\log(\text{Poisson}(N_{obs}, N_{exp}))$  is not added by default to likelihood
  - Use the `Extended()` argument to fit to have it added

```
// Regular maximum likelihood fit
pdf.fitTo(*data) ;

// Extended maximum likelihood fit
pdf.fitTo(*data, Extended(kTRUE)) ;
```

- If p.d.f. is extended,  $N_{exp}$  is default number of events to generate

```
// Generate pdf.expectedEvents() events
RoodataSet* data = pdf.generate(x) ;

// Generate 1000 events
RoodataSet* data = pdf.generate(x, 1000) ;
```

# How it works – Normalization of RooAddPdfs

- Since all component p.d.f.s are normalized, resulting sum of p.d.f.s is automatically normalized
  - As long as sum of coefficients is 1, which is automatically enforced

$$S(x) = c_0 P_0(x) + c_1 P_1(x) + \dots + c_{n-1} P_{n-1}(x) + \left(1 - \sum_{i=0, n-1} c_i\right) P_n(x)$$

- But note that fraction parameter multiplies *normalized* p.d.f.s
- Interpretation of fraction depends on range of observables (and number of observables for >1D)

- If range of observable is changed and fraction parameter is same, the shape effectively different
- Can mitigate this by specifying a fixed reference range for fraction interpretation

```
x.setRange("ref", -20, 20) ;  
pdf->setAddCoefRange("ref") ;
```

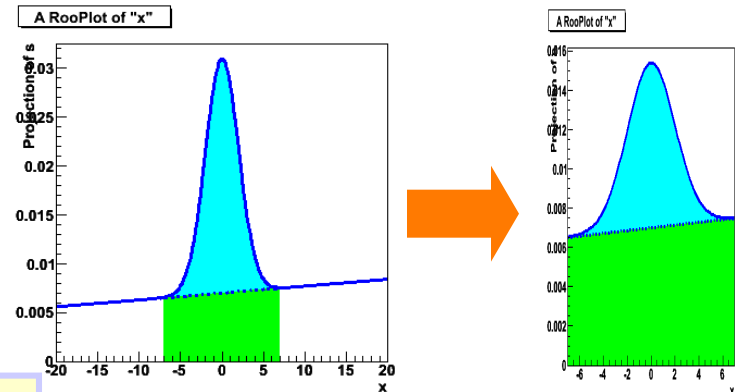

# How it works – event generation of RooAddPdf

- Composite event generation algorithm of **RooAddPdf**
  - Choose randomly a component to generate (probability proportional to coefficient fractions)
  - Delegate generation of observable to algorithm of component p.d.f.
- Allows to efficiently handle sum of p.d.f with very different shapes in most cases
  - Example:
    - Blue Gaussian (internal generator)
    - plus Green Polynomial (accept/reject)

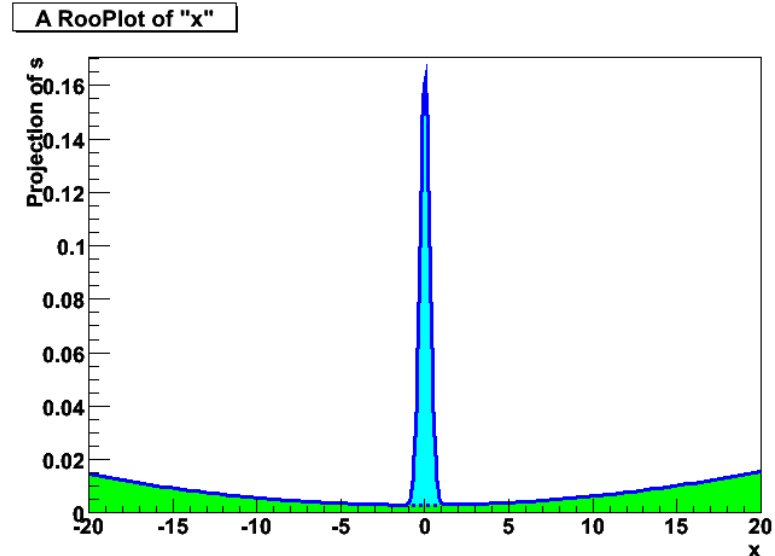



# Dealing with composite p.d.f.s

- A RooAddPdf is an example of a composite p.d.f.
  - The value of the sum is represented by a *tree* of components

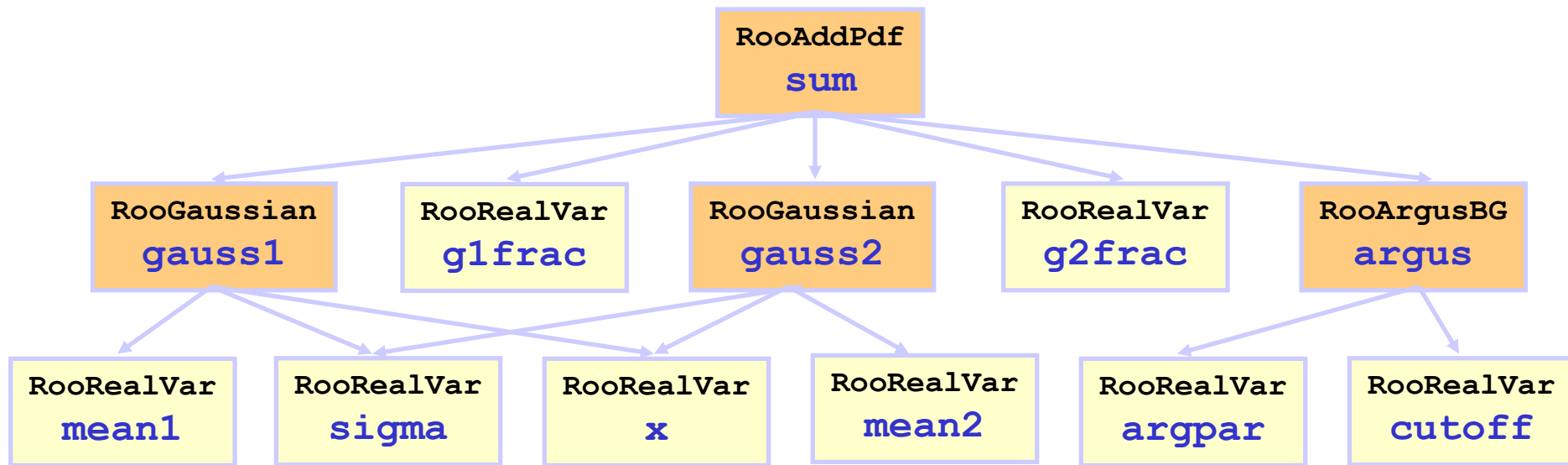

- The compositeness of a p.d.f. is **completely transparent** to most high-level operations
- Can e.g. do `sum->fitTo(*data)` or `sum->generate(x,1000)` without being aware of composite nature of p.d.f.

## Dealing with composite p.d.f.s

---

- The observables reported by a composite p.d.f and the 'leaf' of the expression tree
  - For example, request for list of parameters of composite sum, will return parameters of components of sum

```
RooArgSet *paramList = sum.getParameters(data) ;
paramList->Print("v") ;
RooArgSet::parameters:
  1) RooRealVar::argpar : -1.00000 C
  2) RooRealVar::cutoff : 9.0000 C
  3) RooRealVar::g1frac : 0.50000 C
  4) RooRealVar::g2frac : 0.10000 C
  5) RooRealVar::mean1 : 2.0000 C
  6) RooRealVar::mean2 : 3.0000 C
  7) RooRealVar::sigma : 1.0000 C
```

- In general, composite p.d.f.s work *exactly the same* as basic p.d.f.s.

# Visualization tools for composite objects

---

- Special tools exist to visualize the tree structure of composite objects
  - On the command line

```
Root> sum.Print("t") ;
0x927b8d0 RooAddPdf::sum (g1+g2+a) [Auto]
  0x9254008 RooGaussian::gauss1 (gaussian PDF) [Auto] V
    0x9249360 RooRealVar::x (x) V
      0x924a080 RooRealVar::mean1 (mean of gaussian 1) V
      0x924d2d0 RooRealVar::sigma (width of gaussians) V
    0x9267b70 RooRealVar::g1frac (fraction of gauss1) V
  0x9259dc0 RooGaussian::gauss2 (gaussian PDF) [Auto] V
    0x9249360 RooRealVar::x (x) V
      0x924cde0 RooRealVar::mean2 (mean of gaussian 2) V
      0x924d2d0 RooRealVar::sigma (width of gaussians) V
    0x92680e8 RooRealVar::g2frac (fraction of gauss2) V
  0x9261760 RooArgusBG::argus (Argus PDF) [Auto] V
    0x9249360 RooRealVar::x (x) V
      0x925fe80 RooRealVar::cutoff (argus cutoff) V
      0x925f900 RooRealVar::argpar (argus shape parameter) V
    0x9267288 RooConstVar::0.500000 (0.500000) V
```

# Visualization tools for composite objects

- Interface to GraphViz graph visualization tool

```
'fdp -Tgif sum.dot  
-o sum.gif'
```

```
Root> sum.graphVizTree("sum.dot")
```

```
'dot -Tgif sum.dot  
-o sum.gif'
```



## Putting it all together – Extended unbinned ML Fit to signal and background

```
// Declare observable x
RooRealVar x("x","x",0,10) ;

// Creation of 'sig', 'bkg' component p.d.f.s omitted for clarity

// Model = Nsig*sig + Nbkg*bkg (extended form)
RooRealVar nsig("nsig","#signal events",300,0.,2000.) ;
RooRealVar nbkg("nbkg","#background events",700,0,2000.) ;
RooAddPdf model("model","sig+bkg",RooArgList(sig,bkg),RooArgList(nsig,nbkg)) ;

// Generate a data sample of Nexpected events
RooDataSet *data = model.generate(x) ;

// Fit model to data
model.fitTo(*data, Extended(kTRUE)) ;

// Plot data and PDF overlaid
RooPlot* xframe = x.frame() ;
data->plotOn(xframe) ;
model.plotOn(xframe) ;
model.plotOn(xframe,Components(bkg),
             LineStyle(kDashed)) ;
xframe->Draw() ;
```

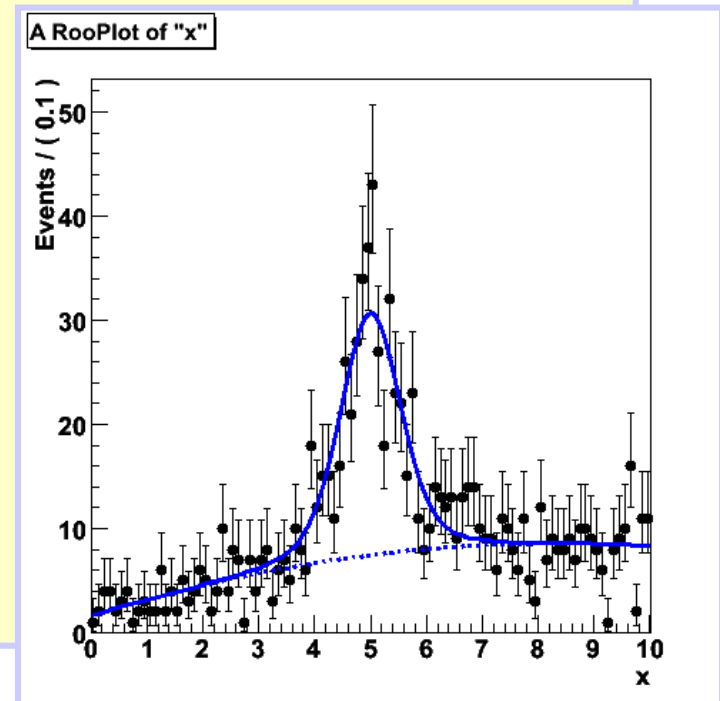

# Building models – Convolutions

- Many experimental observable quantities are well described by convolutions
  - Typically physics distribution smeared with experimental resolution (e.g. for  $B^0 \rightarrow J/\psi K_S$  exponential decay distribution smeared with Gaussian)

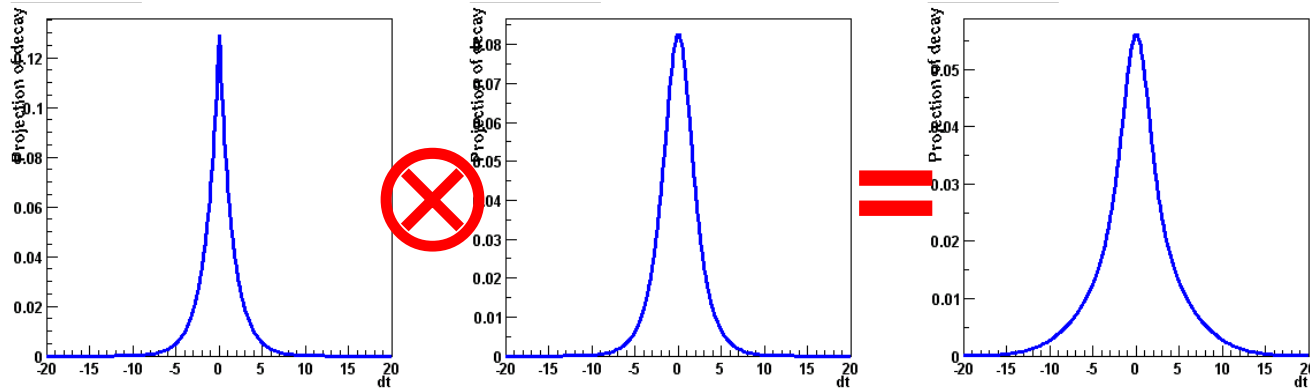

- By explicitly describing observed distribution with a convolution p.d.f can disentangle detector and physics
  - To the extent that enough information is in the data to make this possible

# Mathematical introduction & Numeric issues

---

- Mathematical form of convolution

- Convolution of two functions

$$f(x) \otimes g(x) = \int_{-\infty}^{+\infty} f(x)g(x-x')dx'$$

- Convolution of two normalized p.d.f.s itself is *not* automatically normalized, so expression for convolution p.d.f is

$$F(x) \otimes G(x) = \frac{\int_{-\infty}^{+\infty} F(x)G(x-x')dx'}{\int_{x_{\min}}^{x_{\max}} \int_{-\infty}^{+\infty} F(x)G(x-x')dx'dx}$$

- Because of (multiple) integrations required convolution are difficult to calculate
- Convolution integrals are best done analytically, but often not possible

# Convolution operation in RooFit

---

- RooFit has several options to construct convolution p.d.f.s
  - Class `RooNumConvPdf` – ‘Brute force’ numeric calculation of convolution (and normalization integrals)
  - Class `RooFFTConvPdf` – Calculate convolution integral using discrete FFT technology in fourier-transformed space.
  - Bases classes `RooAbsAnaConvPdf`, `RooResolutionModel`. Framework to construct analytical convolutions (with implementations mostly for B physics)
  - Class `RooVoigtian` – Analytical convolution of non-relativistic Breit-Wigner shape with a Gaussian
- All convolution in one dimension so far
  - N-dim extension of `RooFFTConvPdf` foreseen in future

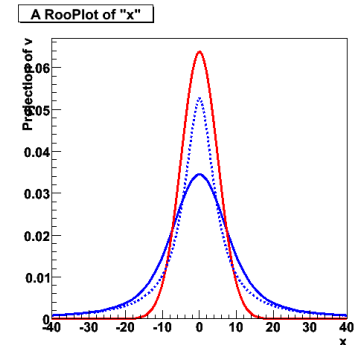



# Numeric convolutions – Class RooNumConvPdf

- Properties of `RooNumConvPdf`
  - Can convolve *any* two input p.d.f.s
  - Uses special numeric integrator that can compute integrals in  $[-\infty, +\infty]$  domain
  - Slow (very!) especially if requiring sufficient numeric precision to allow use in MINUIT (requires  $\sim 10^{-7}$  estimated precision).  
*Converge problems in MINUIT if precision is insufficient*

```
// Construct landau (x) gauss
```

```
RooNumConvPdf lxxg("lxxg","landau (X) gauss",t,landau,gauss) ;
```

*Landau*

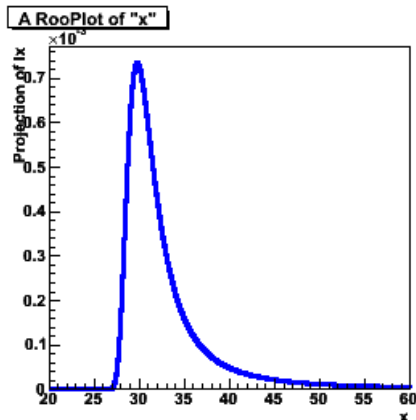

*Gauss*

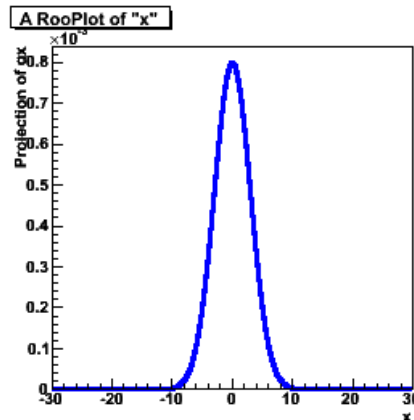

*Landau  $\otimes$  Gauss*

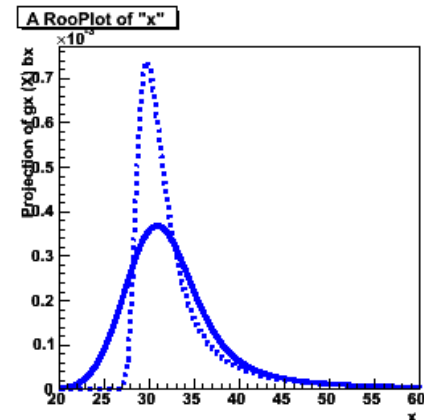

# Numeric convolutions – Class RooFFTConvPdf

- Properties of **RooFFTConvPdf**

- Uses convolution theorem to compute *discrete* convolution in Fourier-Transformed space.
- Transforms both input p.d.f.s with forward FFT

$$X_k = \sum_{n=0}^{N-1} x_n e^{-\frac{2\pi i}{N}kn} \quad k = 0, \dots, N-1 \quad (x_i \text{ are sampled values of p.d.f})$$

- Makes use of Circular Convolution Theorem in Fourier Space

$$\begin{aligned} \mathcal{F}^{-1}\{\mathbf{X} \cdot \mathbf{Y}\}_n &= \sum_{l=0}^{N-1} x_l \sum_{m=-\infty}^{\infty} y_m \left( \sum_{p=-\infty}^{\infty} \delta_{m(n-l-pN)} \right) \\ &= \sum_{l=0}^{N-1} x_l \sum_{p=-\infty}^{\infty} \left( \sum_{m=-\infty}^{\infty} y_m \cdot \delta_{m(n-l-pN)} \right) \\ &= \sum_{l=0}^{N-1} x_l \left( \sum_{p=-\infty}^{\infty} y_{n-l-pN} \right) \stackrel{\text{def}}{=} (\mathbf{x} * \mathbf{y}_N)_n, \end{aligned}$$

- *Convolution can be computed in terms of products of Fourier components (easy)*
- Apply inverse Fourier transform to obtained convoluted p.d.f in space domain

$$x_n = \frac{1}{N} \sum_{k=0}^{N-1} X_k e^{\frac{2\pi i}{N}kn} \quad n = 0, \dots, N-1.$$

# Numeric convolutions – Class RooFFTConvPdf

---

- Fourier transforms calculated by FFTW3 package
  - Interfaced in ROOT through `TVirtualFFT` class
- About **100x faster** than `RooNumConvPdf`
  - Also much better numeric stability (c.f. MINUIT converge)
  - Choose sufficiently large number of samplings to obtain smooth output p.d.f
  - CPU time is **not** proportional to number of samples, e.g. 10000 bins works fine in practice
- Note: p.d.f.s are not sampled from  $[-\infty, +\infty]$ , but from  $[x_{\min}, x_{\max}]$
- Note: p.d.f is explicitly treated as *cyclical* beyond range
  - Excellent for cyclical observables such as angles
  - If p.d.f converges to zero towards both ends of range if non-cyclical observable, all works out fine
  - If p.d.f does not converge to zero towards domain end, cyclical leakage will occur

# Numeric convolutions – Class RooFFTConvPdf

- Usage example

```
// Construct landau (x) gauss (10000 samplings 2nd order interpolation)  
t.setBins(10000,"cache") ;  
RooFFTConvPdf l1xg("l1xg","landau (X) gauss",t,landau,gauss,2) ;
```

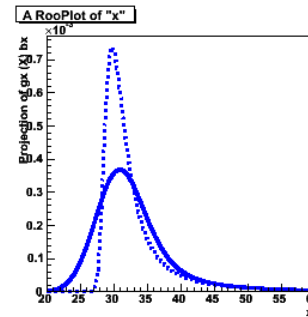
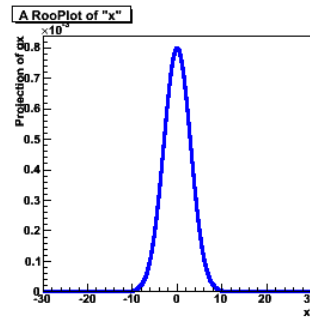
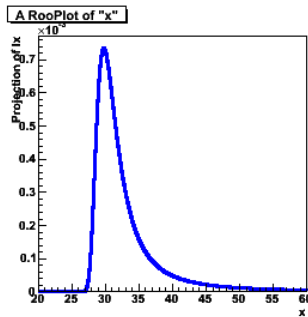

- Example with cyclical 'leakage'

- Can reduce this by specifying a 'buffer zone' in FFT calculation beyond end of ranges

`conv.setBufferFraction(0.3)`

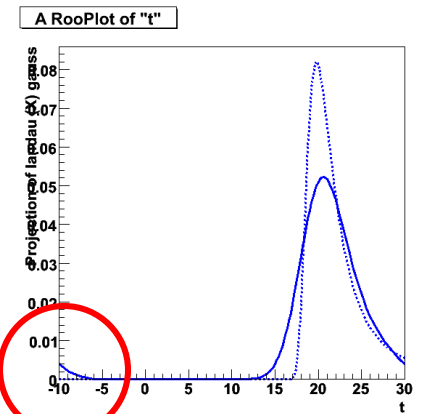

- Convoluted PDFs that can be written in the following form can be used in a very modular way in RooFit

$$P(dt, \dots) = \sum_k c_k(\dots) (f_k(dt, \dots) \otimes R(dt, \dots))$$

coefficient      'basis function'      resolution function

Example:  $B^0$  decay with mixing

$$c_0 = 1 \pm \Delta w, \quad f_0 = e^{-|t|/\tau}$$

$$c_1 = \pm(1 - 2w), \quad f_1 = e^{-|t|/\tau} \cos(\Delta m \cdot t)$$

# Convolved PDFs

---

- Physics model and resolution model are implemented separately in RooFit

Implements  $f_i(dt, \dots) \otimes R(dt, \dots)$   
Also a PDF by itself

**RooResolutionModel**

$$P(dt, \dots) = \sum_k c_k(\dots) \underbrace{(f_k(dt, \dots) \otimes R(dt, \dots))}_{\text{RooConvolvedPdf (physics model)}}$$

**RooConvolvedPdf** (physics model)

Implements  $\mathbf{c}_k$   
Declares list of  $\mathbf{f}_k$  needed

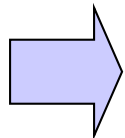

User can choose combination of physics model  
and resolution model at run time

(Provided resolution model implements all  $f_k$  declared by physics model)

# Convolved PDFs

```
RooRealVar dt("dt","dt",-10,10) ;  
RooRealVar tau("tau","tau",1.548) ;  
  
// Truth resolution model  
RooTruthModel tm("tm","truth model",dt) ;  
  
// Unsmeared decay PDF  
RooDecay decay_tm("decay_tm","decay",  
    dt,tau,tm,RooDecay::DoubleSided) ;  
  
// Gaussian resolution model  
RooRealVar bias1("bias1","bias1",0) ;  
RooRealVar sigma1("sigma1","sigma1",1) ;  
RooGaussModel gm1("gm1","gauss model",  
    dt,bias1,sigma1) ;  
  
// Construct a decay (x) gauss PDF  
RooDecay decay_gm1("decay_gm1","decay",  
    dt,tau,gm1,RooDecay::DoubleSided) ;
```

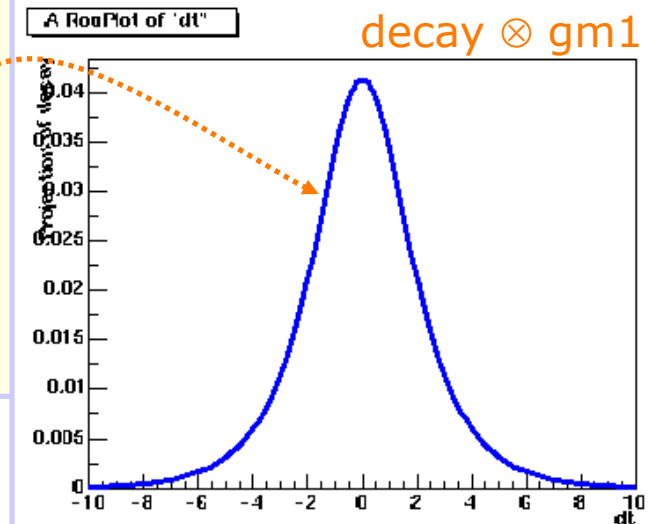
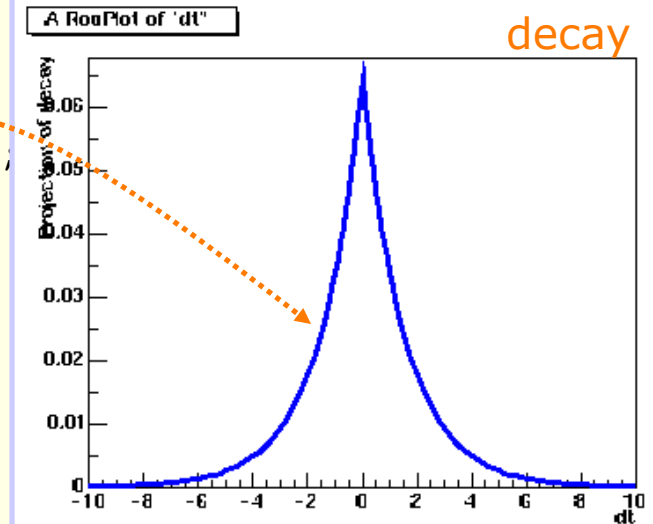

# Composite Resolution Models: RooAddModel

```
//... (continued from last page)

// Wide gaussian resolution model
RooRealVar bias2("bias2","bias2",0) ;
RooRealVar sigma2("sigma2","sigma2",5) ;
RooGaussModel gm2("gm2","gauss model 2"
                  ,dt,bias2,sigma2) ;

// Build a composite resolution model
RooRealVar f("f","fraction of gm1",0.5)
RooAddModel gmsum("gmsum","gm1+gm2",
                  RooArgList(gm1, gm2), f) ;

// decay (x) (gm1 + gm2)
RooDecay decay_gmsum("decay_gmsum",
                    "decay",dt,tau, gmsum,
                    RooDecay::DoubleSided) ;
```

→RooAddModel works like RooAddPdf

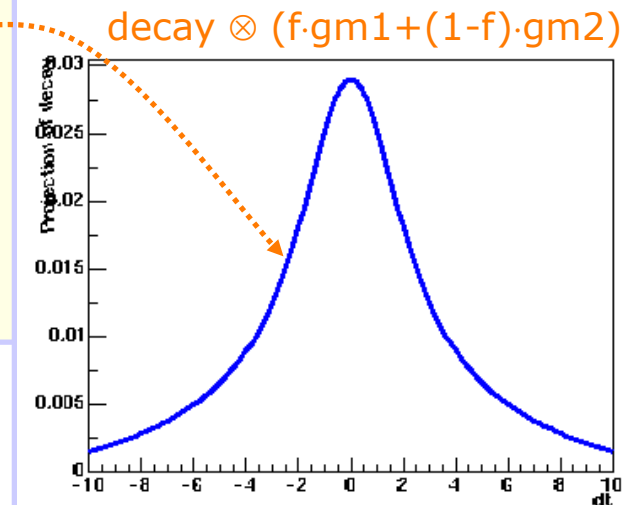
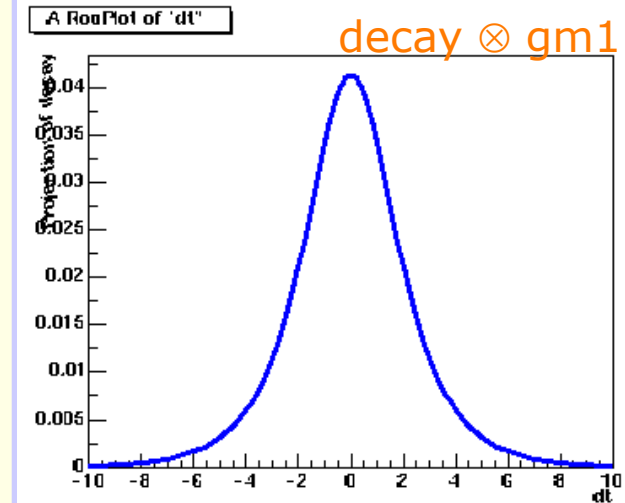



# Resolution models

- Currently available resolution models
  - `RooGaussModel` – Gaussian with bias and sigma
  - `RooGExpModel` – Gaussian (X) Exp with sigma and lifetime
  - `RooTruthModel` – Delta function
- A `RooResolutionModel` is also a PDF
  - You can use the same resolution model you use to convolve your physics PDFs to fit to MC residuals

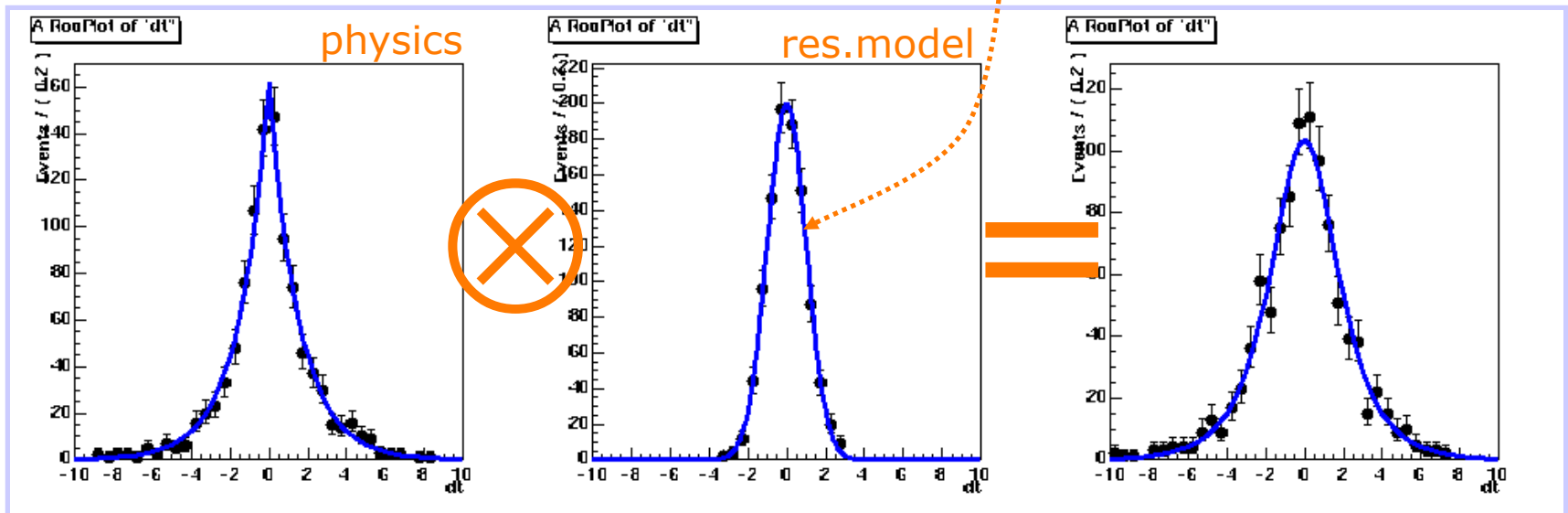

## How it works – generating events from convolution p.d.f.s

---

- A very efficient implementation of event generation is possible

$$\mathcal{X}_{P \otimes R} = \mathcal{X}_P + \mathcal{X}_R$$

- Reflect 'smearing' view of convolution
- Very fast as no computation of convolution integrals is required
- But only if both input p.d.f.s can generate observables in the range  $[-\infty, +\infty]$  which is not possible with accept/reject so this can only be done if both input p.d.f.s have an internal generator implementation
- If above conditions are not met, automatic fallback solution is to perform accept/reject sampling on convoluted p.d.f. shape

# 4 Multidimensional models

- *Uncorrelated products of p.d.f.s*
- *Using composition to p.d.f.s with correlation*
- *Products of conditional and plain p.d.f.s*

# Building realistic models

## - Multiplication

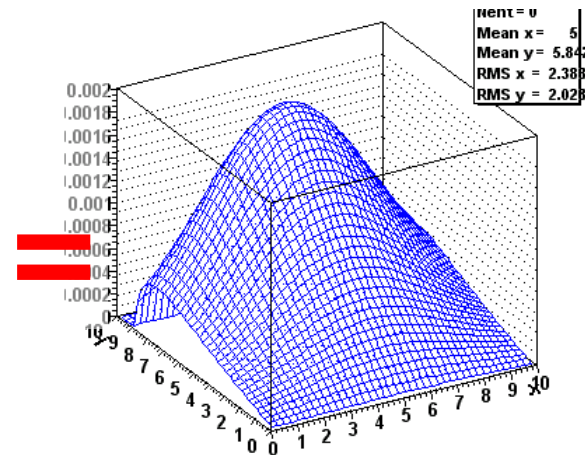
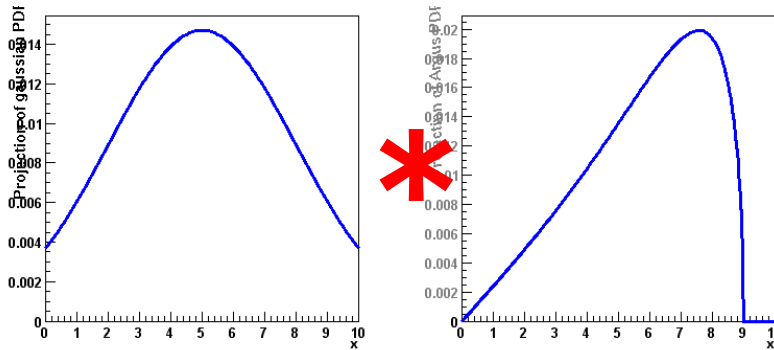

## - Composition

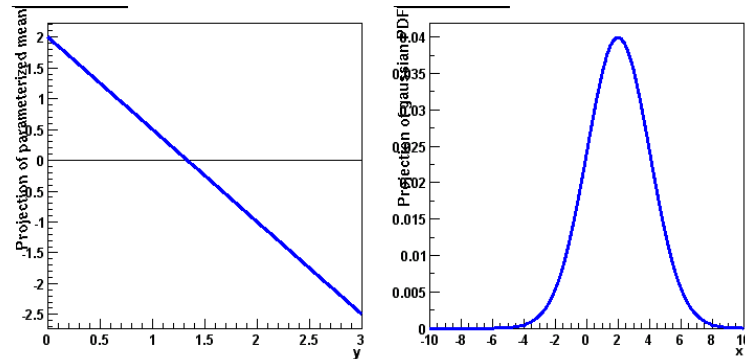

$$m(y; a_0, a_1)$$

$$g(x; m, s)$$

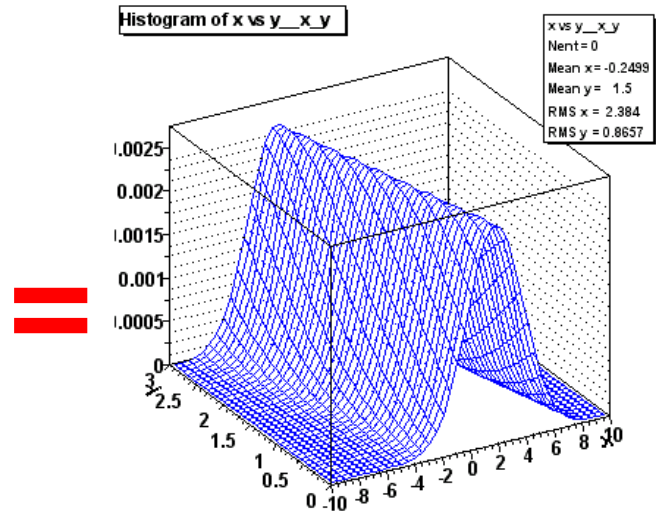

$$g(x, y; a_0, a_1, s)$$

Possible in any PDF

No explicit support in PDF code needed

# Model building – Products of uncorrelated p.d.f.s

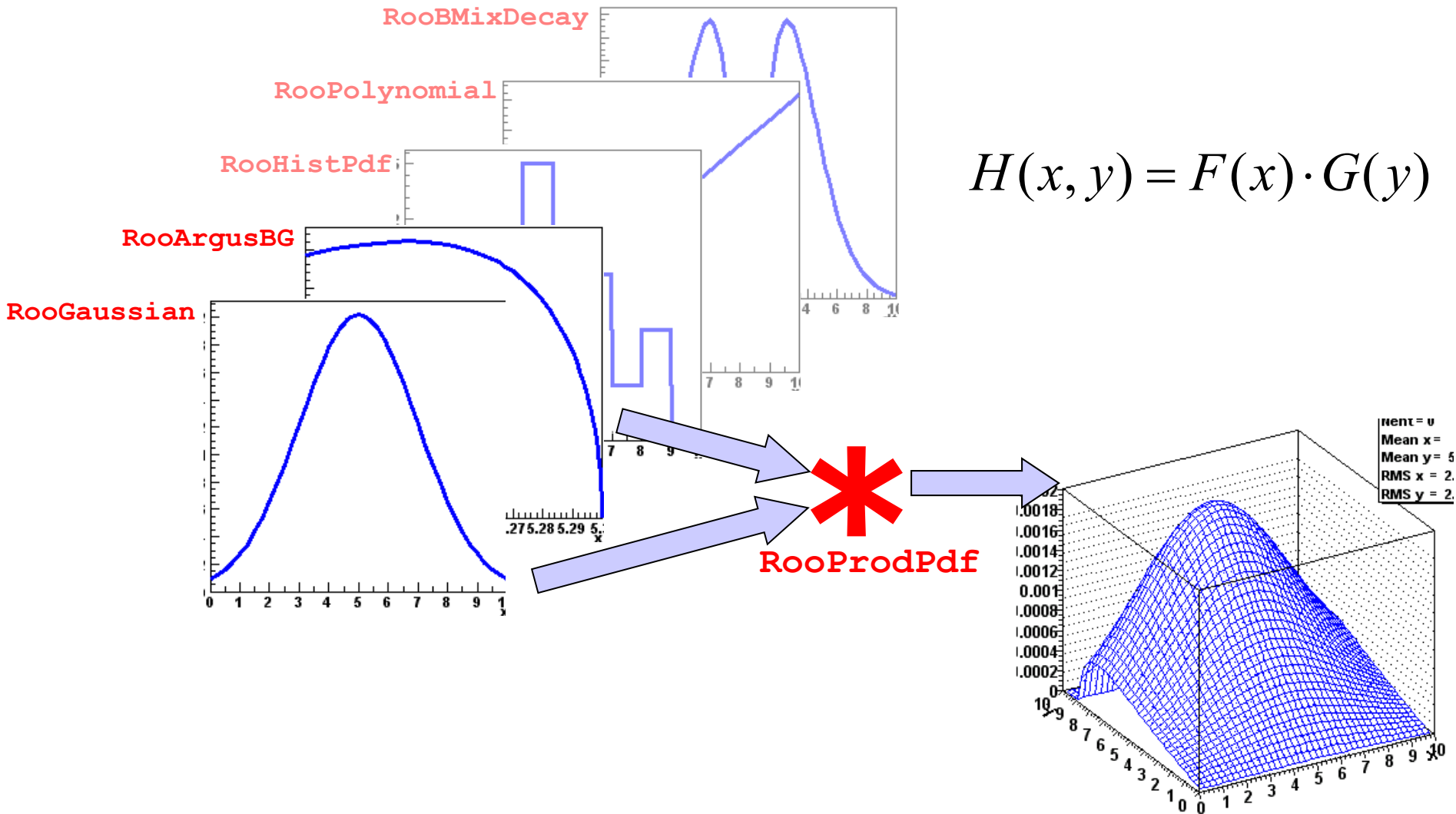

## Uncorrelated products – Mathematics and constructors

---

- Mathematical construction of products of uncorrelated p.d.f.s is straightforward

**2D**

$$H(x, y) = F(x) \cdot G(y)$$

**nD**

$$H(x^{\{i\}}) = \prod_i F^{\{i\}}(x^{\{i\}})$$

- No explicit normalization required → If input p.d.f.s are unit normalized, product is also unit normalized (this is true *only* because of the absence of correlations)
- Corresponding RooFit operator p.d.f. is **RooProdPdf**
  - Returns product of *normalized* input p.d.f values

```
RooGaussian gx("gx", "gaussian PDF", x, meanx, sigmax) ;
RooGaussian gy("gy", "gaussian PDF", y, meany, sigmay) ;

// Multiply gaussx and gaussy into a two-dimensional p.d.f. gaussxy
RooProdPdf gaussxy("gxy", "gx*gy", RooArgList(gx, gy)) ;
```

# How it work – event generation on uncorrelated products

- If p.d.f.s are uncorrelated, each observable can be generated separately
  - Reduced dimensionality of problem (important for e.g. accept/reject sampling)
  - Actual event generation delegated to component p.d.f (can e.g. use internal generator if available)
  - **RooProdPdf** just aggregates output in single dataset

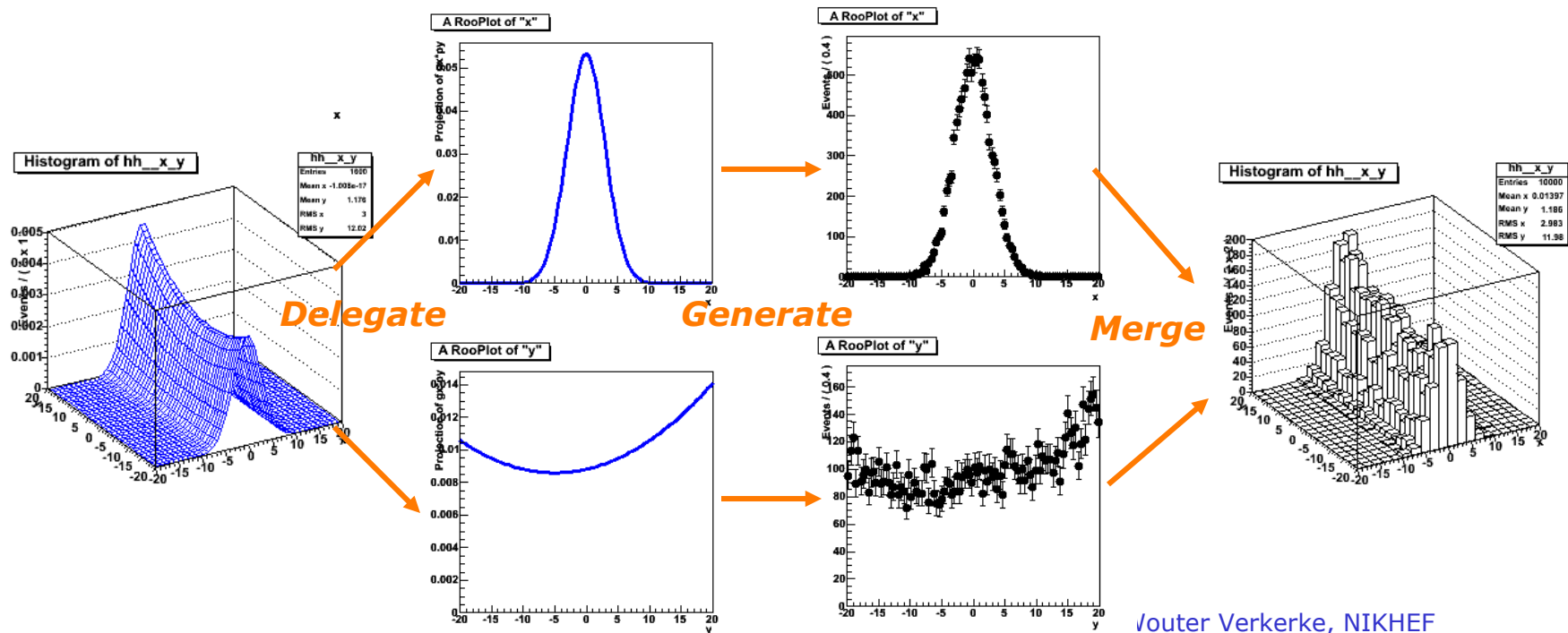

# Fundamental multi-dimensional p.d.fs

- It also possible define multi-dimensional p.d.f.s that do not arise through a product construction
  - For example

```
RooGenericPdf gp("gp", "sqrt(x+y)*sqrt(x-y)", RooArgSet(x,y)) ;
```

- But *usually*  $n$ -dim p.d.f.s are constructed more intuitively through product constructs. Also correlations can be introduced efficiently (more on that in a moment)

- Example of fundamental 2-D B-physics p.d.f. **RooBMixDecay**

- Two observables:
  - decay time* (t, continuous)
  - mixingState* (m, discrete [-1,+1])

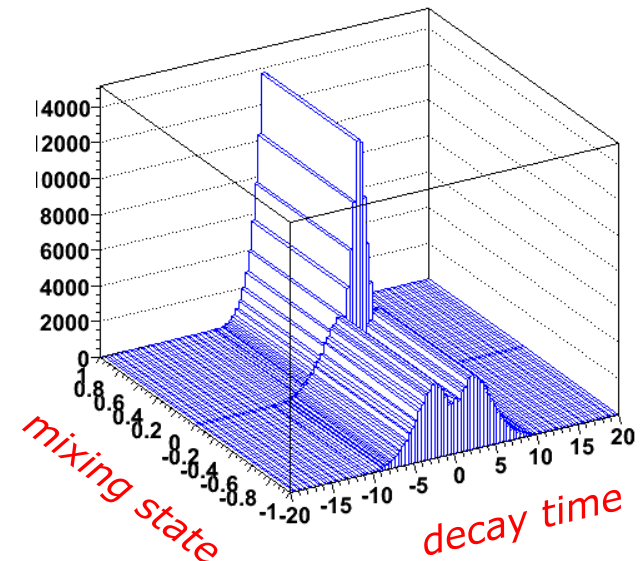



# Plotting multi-dimensional PDFs

```
RooPlot* xframe = x.frame() ;  
data->plotOn(xframe) ;  
prod->plotOn(xframe) ;  
xframe->Draw() ;
```

$$f(x) = \int pdf(x, y) dy$$

```
c->cd(2) ;  
RooPlot* yframe = y.frame() ;  
data->plotOn(yframe) ;  
prod->plotOn(yframe) ;  
yframe->Draw() ;
```

$$f(y) = \int pdf(x, y) dx$$

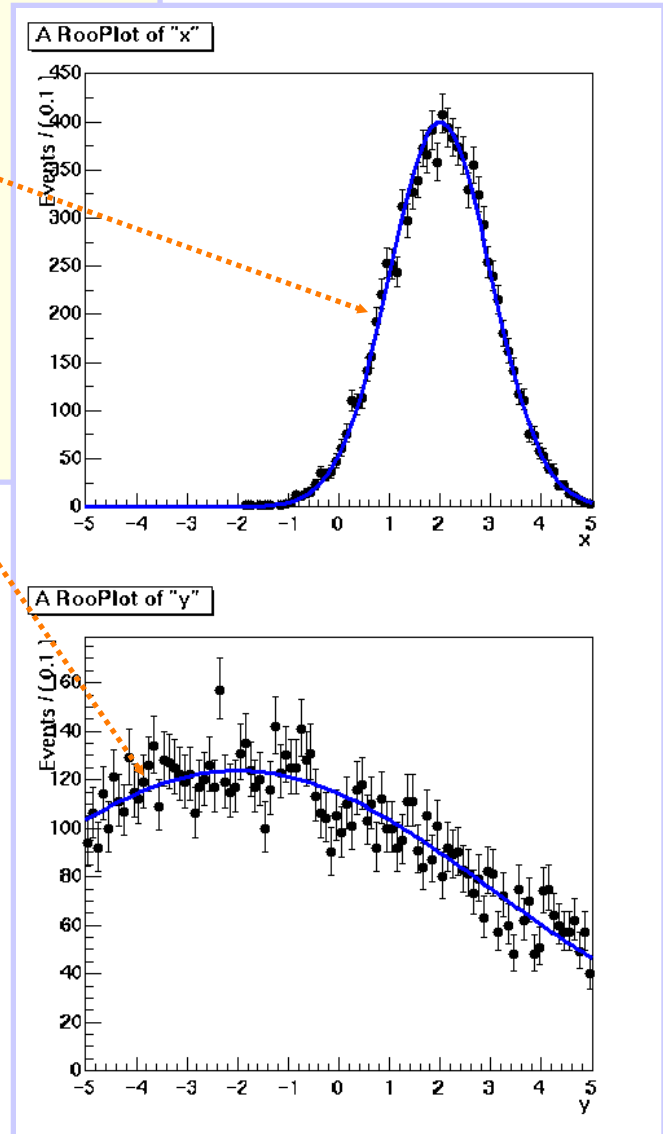

- Plotting a dataset  $D(x,y)$  versus  $x$  represents a *projection over  $y$*
- To overlay  $PDF(x,y)$ , you must plot  $\int dy PDF(x,y)$
- RootFit automatically takes care of this!**
  - RooPlot remembers dimensions of plotted datasets

# Projecting out hidden dimensions

- Example in 2 dimensions
  - 2-dim dataset  $D(x,y)$
  - 2-dim PDF  $P(x,y)=\text{gauss}(x)*\text{gauss}(y)$

- 1-dim plot versus x

$$P_p(x) = \frac{\int p(x,y)dy}{\int p(x,y)dxdy}$$

- 1-dim plot versus y

$$P_p(y) = \frac{\int p(x,y)dx}{\int p(x,y)dxdy}$$

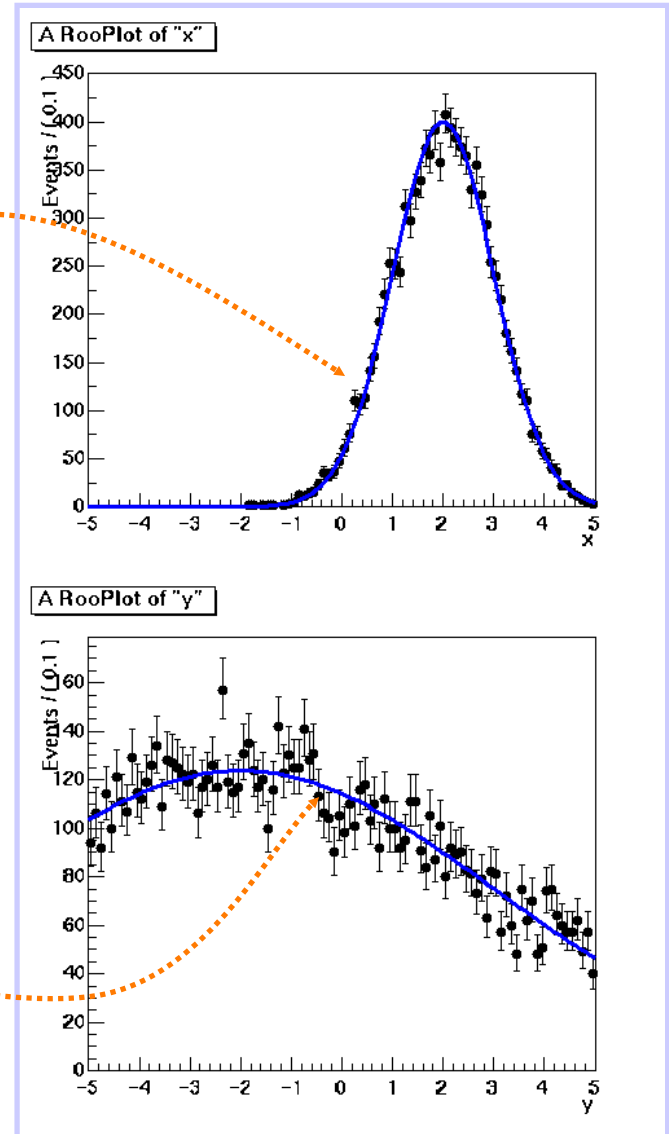

# RooProdPdf automatic optimization for uncorrelated terms

- Example in 2 dimensions
  - 2-dim dataset  $D(x,y)$
  - 2-dim PDF  $P(x,y)=\text{gaus}(x)*\text{gauss}(y)$
- 1-dim plot versus  $x$

$$P_p(x) = \frac{\int g(x)g(y)dy}{\int g(x)g(y)dxdy} = \frac{g(x)\int g(y)dy}{\int g(x)dx\int g(y)dy} = \frac{g(x)}{\int g(x)dx}$$

- 1-dim plot versus  $y$

$$P_p(y) = \frac{\int g(x)g(y)dx}{\int g(x)g(y)dxdy} = \frac{\int g(x)dx \cdot g(y)}{\int g(x)dx\int g(y)dy} = \frac{g(y)}{\int g(y)dy}$$

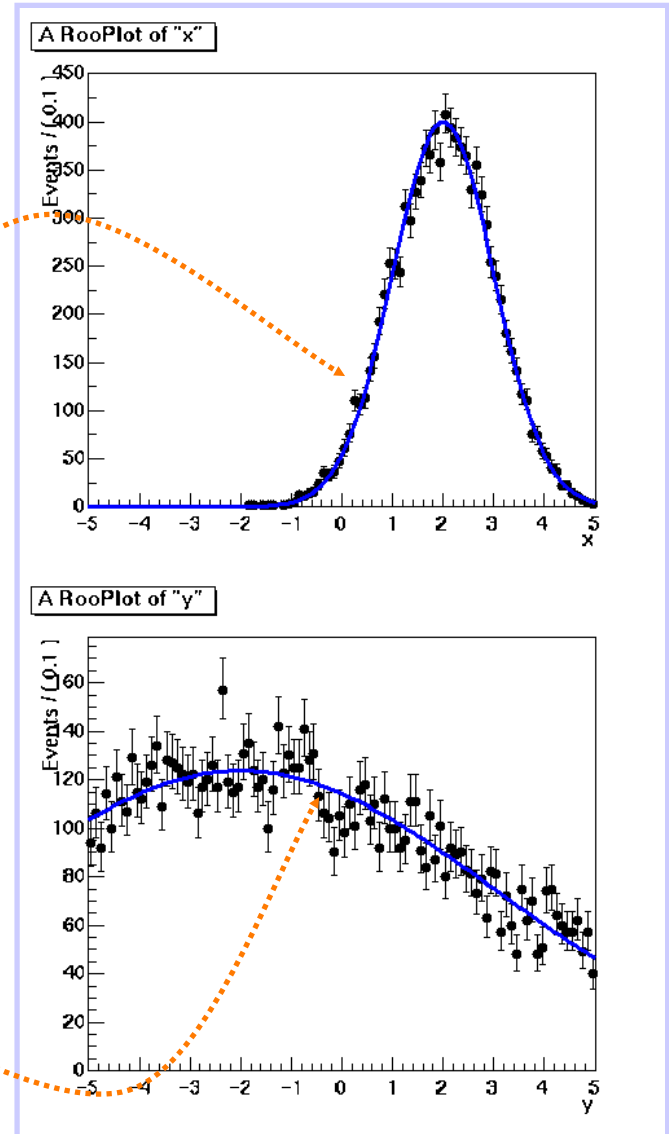

# Introduction to slicing

- With multidimensional p.d.f.s it is also often useful to be able to plot a slice of a p.d.f
- In RooFit
  - A *slice* is thin
  - A *range* is thick
- Slices mostly useful in discrete observables
  - A slice in a continuous observable has no width and usually no data with the corresponding cut (e.g. "x=5.234")
- Ranges work for both continuous and discrete observables
  - Range of discrete observable can be list of  $\geq 1$  state

Slice in x

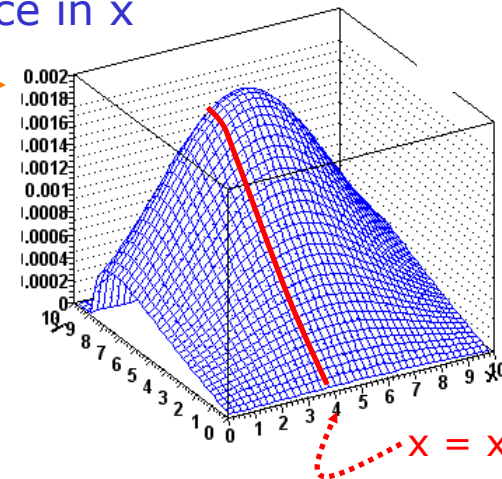

Range in y

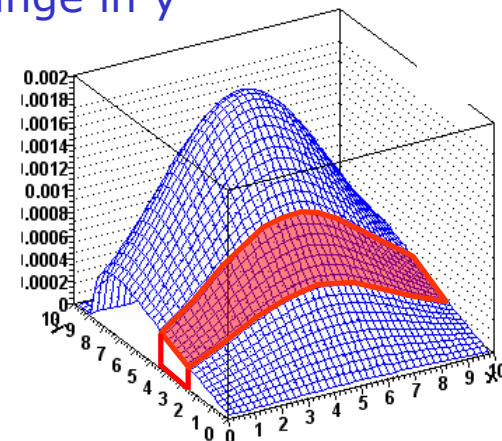

# Plotting a *slice* of a dataset

- Use the optional cut string expression

```
// Mixing dataset defines dt,mixState
RooDataSet* data ;

// Plot the entire dataset
RooPlot* frame = dt.frame() ;
data->plotOn(frame) ;

// Plot the mixed part of the data
RooPlot* frame_mix = dt.frame() ;
data->plotOn(frame,
              Cut("mixState==mixState::mixed"))
```

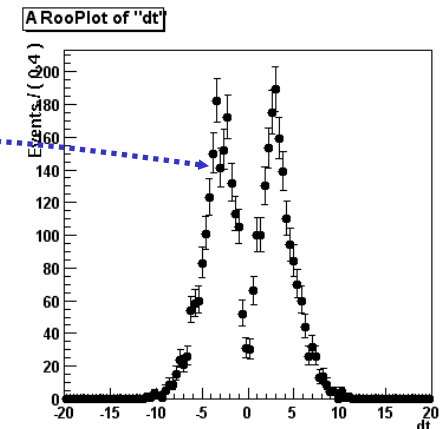
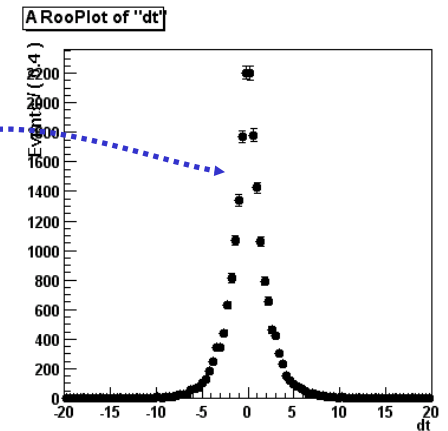

- Works the *same* for *binned data* sets

# Plotting a *slice* of a p.d.f

```
RooPlot* dtframe = dt.frame() ;  
data->plotOn(dtframe, Cut("mixState==mixState::mixed")) ;  
  
mixState = "mixed" ;  
bmix.plotOn(dtframe, Slice(mixState)) ;  
dtframe->Draw() ;
```

Slice is positioned at 'current' value of sliced observable

For slices both data and p.d.f normalize with respect to full dataset. If fraction 'mixed' in above example disagrees between data and p.d.f prediction, this discrepancy will show in plot

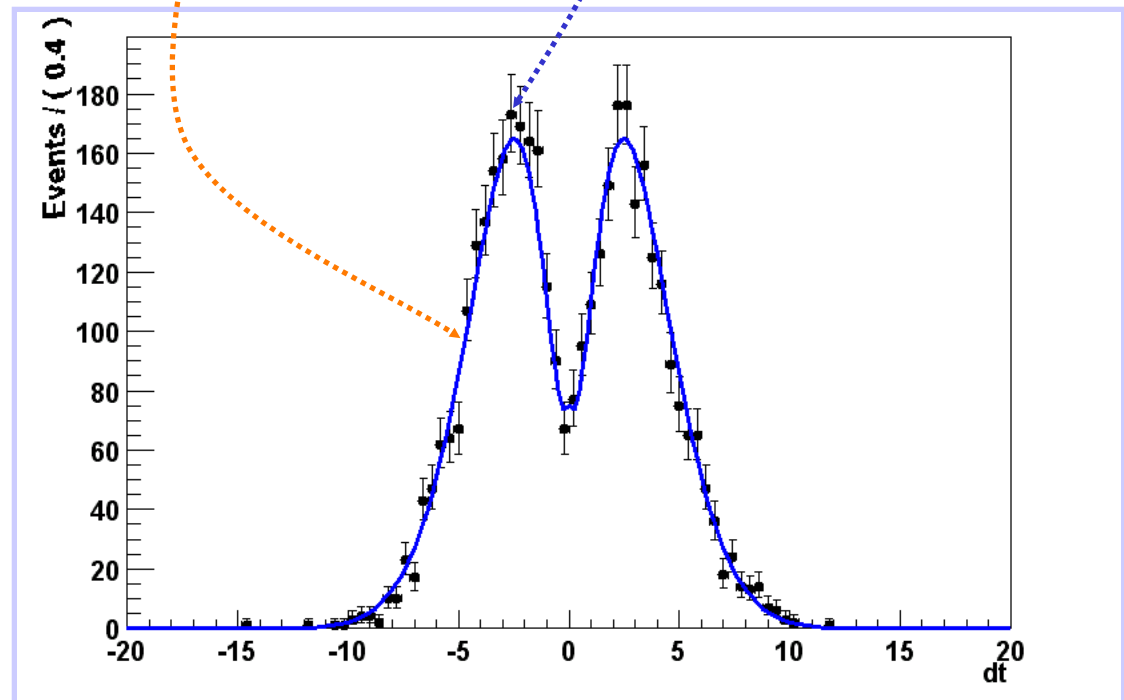
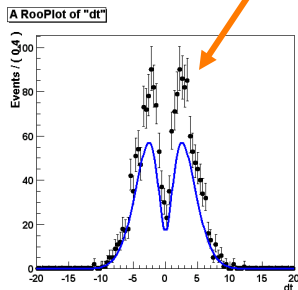

# Plotting a *range* of a p.d.f and a dataset

$$\text{model}(x,y) = \text{gauss}(x)*\text{gauss}(y) + \text{poly}(x)*\text{poly}(y)$$

```
RooPlot* xframe = x.frame() ;  
data->plotOn(xframe) ;  
model.plotOn(xframe) ;
```

```
y.setRange("sig",-1,1) ;  
RooPlot* xframe2 = x.frame() ;  
data->plotOn(xframe2,CutRange("sig")) ;  
model.plotOn(xframe2,ProjectionRange("sig")) ;
```

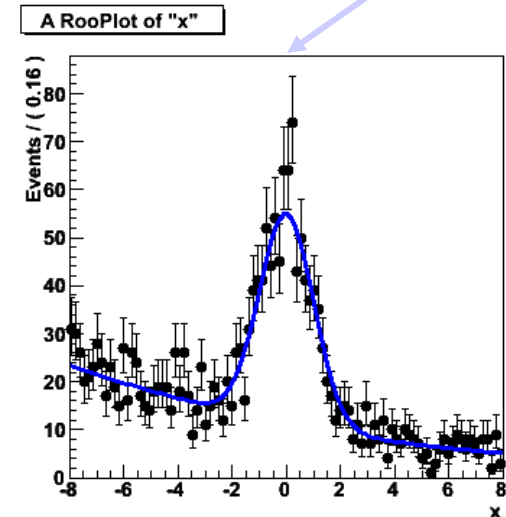
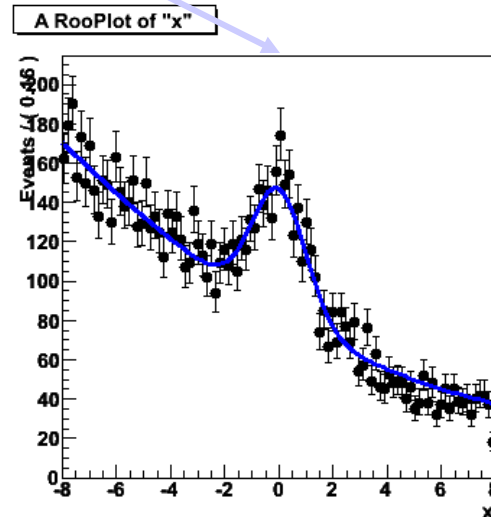
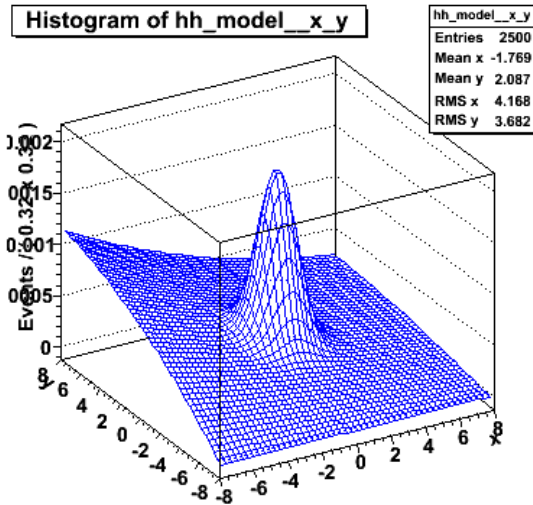

→ Works also with >2D projections (just specify projection range on all projected observables)

→ Works also with multidimensional p.d.fs that have correlations

# Physics example of combined range and slice plotting

Example setup:

Argus (mB) \* Decay (dt) + (background)  
Gauss (mB) \* BMixDecay (dt) (signal)

```
// Plot projection on mB
RooPlot* mbframe = mb.frame(40) ;
data->plotOn(mbframe) ;
model.plotOn(mbframe) ;

// Plot mixed slice projection on deltat
RooPlot* dtframe = dt.frame(40) ;
data>plotOn(dtframe,
              Cut("mixState==mixState::mixed")) ;
mixState="mixed" ;
model.plotOn(dtframe, Slice(mixState)) ;
```

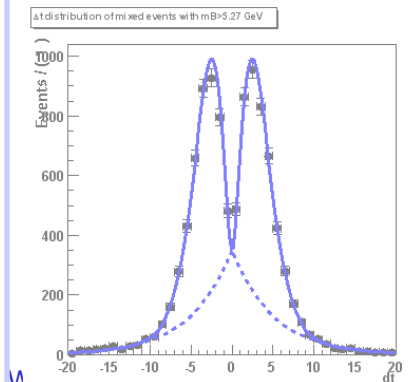
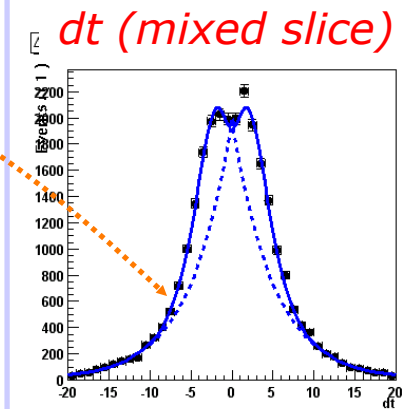
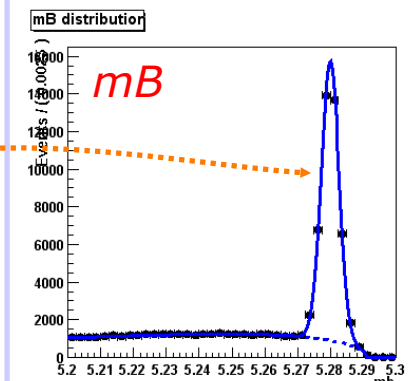



# Plotting slices with finite width - Example

"signal"

Example setup:

Argus (mB) \* Decay (dt) + (background)  
Gauss (mB) \* BMixDecay (dt) (signal)

```
mb.setRange("signal", 5.27, 5.30) ;  
  
mbSliceData->plotOn(dtframe2,  
    Cut("mixState==mixState::mixed"),  
    CutRange("signal"))  
  
model.plotOn(dtframe2, Slice(mixState),  
    ProjectionRange("signal"))
```

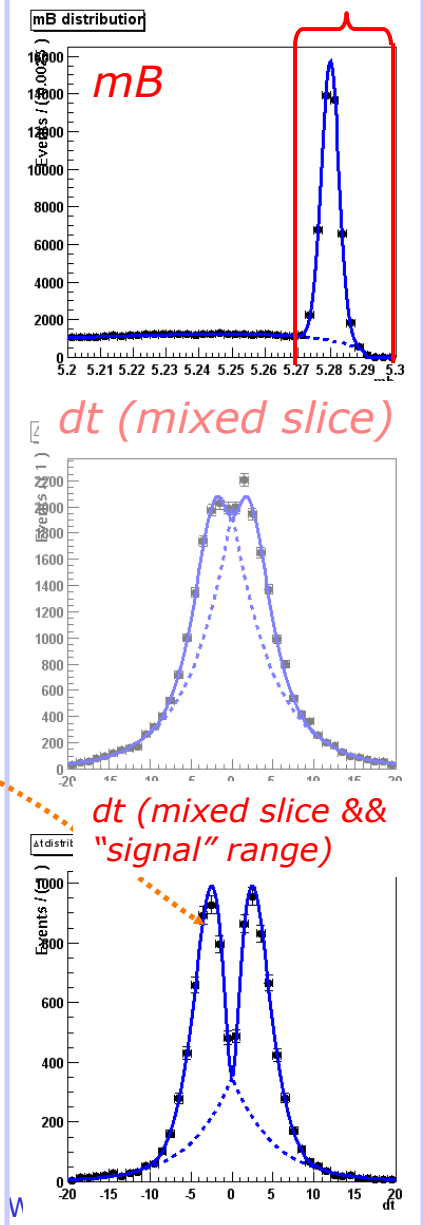

# Plotting slices with finite width - Example

- We can also plot the finite width slice with a different technique → toy MC integration

```
// Generate 80K toy MC events from p.d.f to be projected
RooDataSet *toyMC =
    model.generate(RooArgSet(dt,mixState,tagFlav,mb),80000);

// Apply desired cut on toy MC data
RooDataSet* mbSliceToyMC = toyMC->reduce("mb>5.27");

// Plot data requesting data averaging over selected toy MC data
model.plotOn(dtframe2,Slice(mixState),ProjWData(mb,mbSliceToyMC))
```

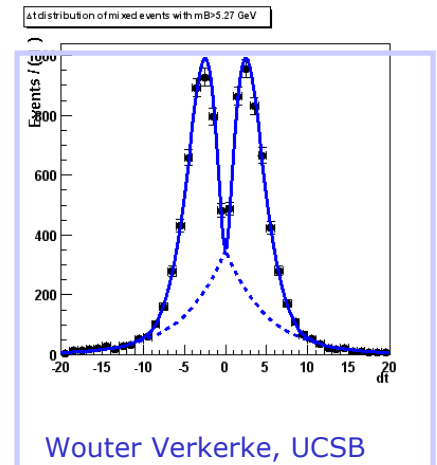

# Plotting non-rectangular PDF regions

---

- Why is this interesting? Because with this technique we can trivially implement projection over **arbitrarily shaped regions**.
  - Any cut prescription that you can think of to apply to data works
- Example: Likelihood ratio projection plot
  - Common technique in rare decay analyses
  - PDF typically consist of N-dimensional event selection PDF, where N is large (e.g. 6.)
  - Projection of data & PDF in any of the N dimensions doesn't show a significant excess of signal events
  - To demonstrate purity of selected signal, plot data distribution (with overlaid PDF) in one dimension, **while selecting events with a cut on the likelihood ratio of signal and background in the remaining N-1 dimensions**

# Plotting data & PDF with a likelihood ratio cut

- Simple example
  - 3 observables (x,y,z)
  - Signal shape:  $\text{gauss}(x) \cdot \text{gauss}(y) \cdot \text{gauss}(z)$
  - Background shape:  $(1+a \cdot x)(1+b \cdot y)(1+c \cdot z)$
  - Plot distribution in x

```
// Plot x distribution of all events  
RooPlot* xframe1 = x.frame(40) ;  
data->plotOn(xframe1) ;  
sum.plotOn(xframe1) ;
```

Integrated projection of data/PDF on X doesn't reflect signal/background discrimination power of PDF in y,z

Use LR ratio technique to only plot events with are signal-like according to p.d.f in projected observable (y,z)

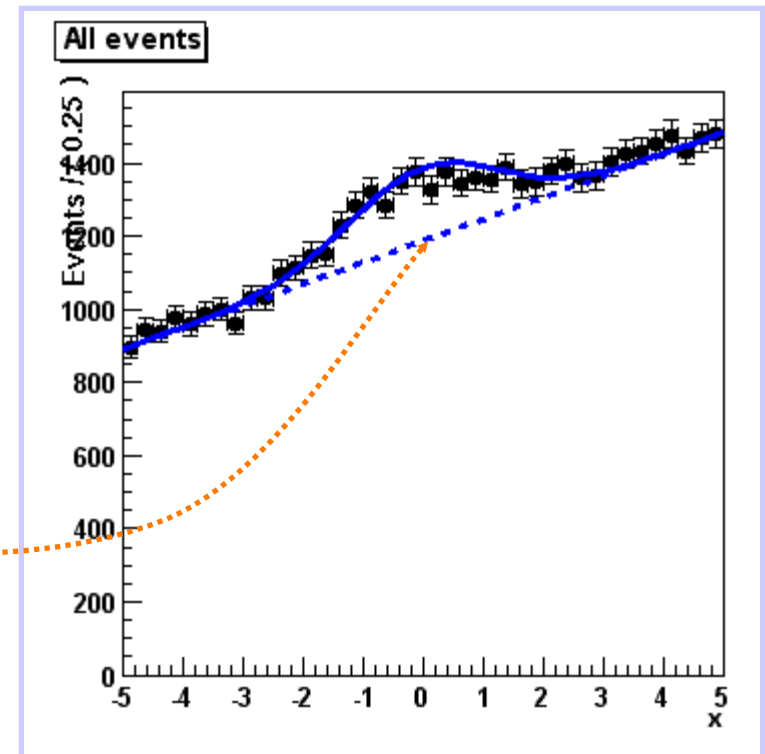

## Plotting data & PDF with a likelihood ratio cut

---

- Given a p.d.f. with three observable (x,y,z)  
how do you calculate the  $S'(y,z)/(S'(y,z)+B'(y,z))$  L ratio
- First calculate projected likelihoods  $S'$  and  $B'$ 
  - Use the built-in createProjection method which returns a projection of a given p.d.f.s

```
RooAbsPdf* sigYZ = sig->createProjection(x) ;  
RooAbsPdf* totYZ = model->createProjection(x) ;
```

- The calculate ratio for each event

```
// Formula expression of LR  
RooFormulaVar LR("LR", "-log(sigYZ) - (-log(totYZ))",  
                RooArgSet(*sigYX,*totYZ)) ;  
  
// Add column to dataset with precalculate value of LR  
data->addColumn(LR) ;
```

# Plotting data & PDF with a likelihood cut

- Look at distribution of per-event LR in toy MC sample and decide on suitable cut

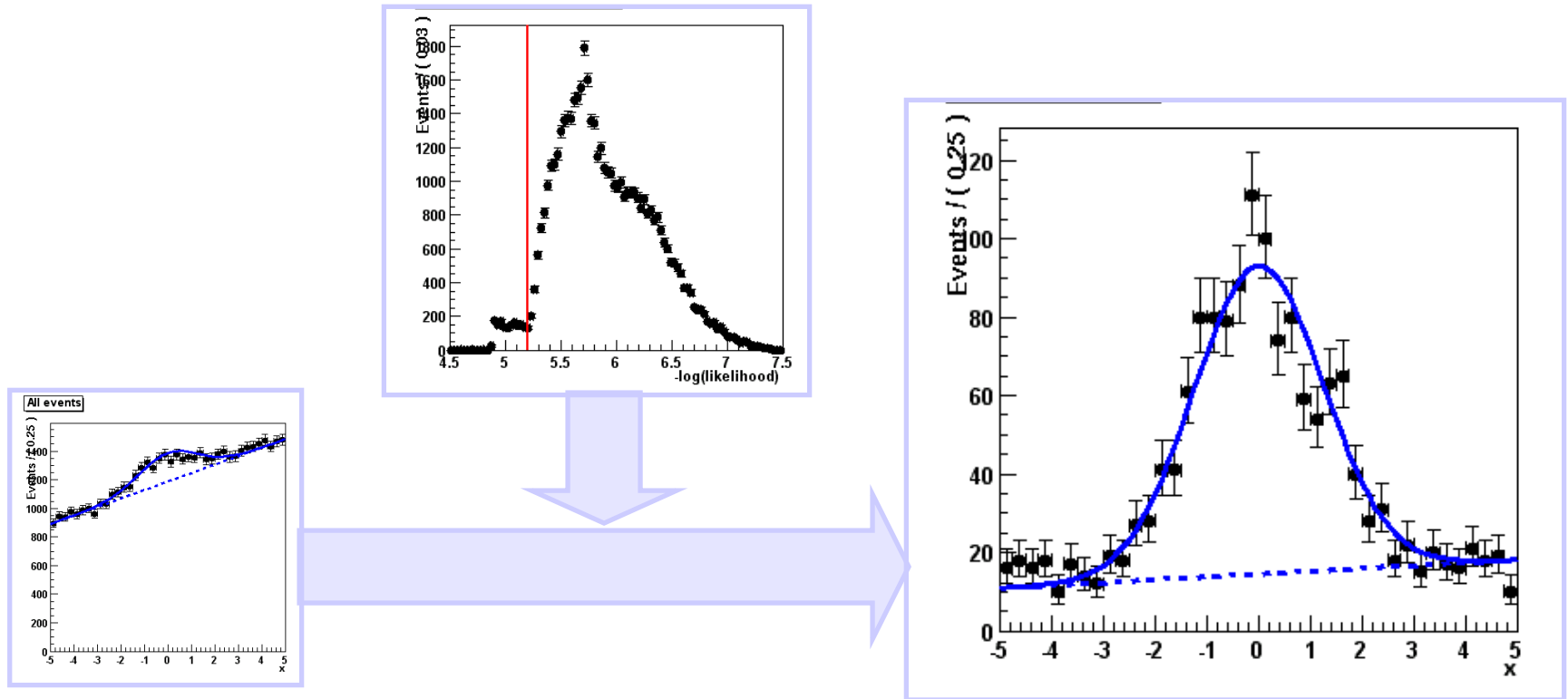

Wouter Verkerke, NIKHEF

- Apply cut to both data sample and toyMC sample for projection and make plot

# Plotting in more than 2,3 dimensions

- No equivalent of RooPlot for >1 dimensions
  - Usually >1D plots are not overlaid anyway
- Easy to use `createHistogram()` methods provided in both `RooAbsData` and `RooAbsPdf` to fill ROOT 2D,3D histograms

```
TH2D* ph2 = pdf.createHistogram("ph2",x,YVar(y)) ;  
  
TH2* dh2 = data.createHistogram("dg2",x,Binning(10),  
                                YVar(y,Binning(10))) ;  
  
ph2->Draw("SURF") ;  
dh2->Draw("LEGO") ;
```

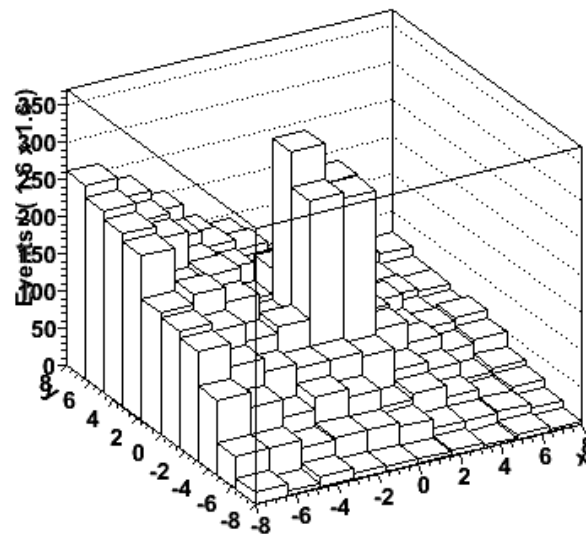
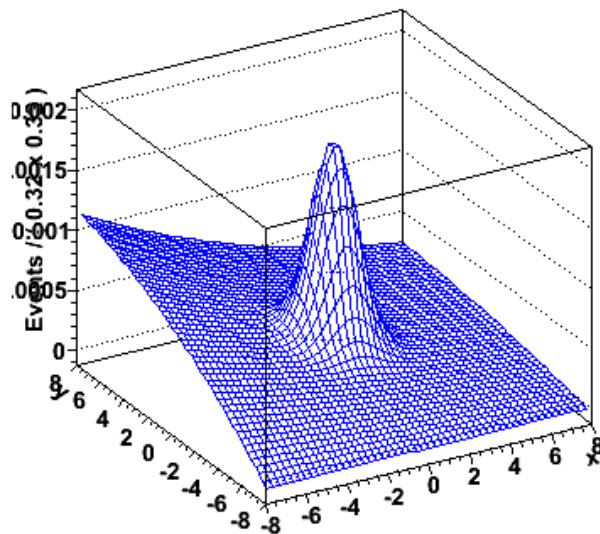

# Building models – Introducing correlations

---

- Easiest way to do this is
  - start with 1-dim p.d.f. and change one of its parameters into a function that depends on another observable

$$f(x; p) \Rightarrow f(x, p(y, q)) = f(x, y; q)$$

- Natural way to think about it
- Example problem
  - Observable is reconstructed mass  $M$  of some object.
  - Fitting Gaussian  $g(M, \text{mean}, \text{sigma})$  some background to dataset  $D(M)$
  - But reconstructed mass has *bias* depending on some other observable  $X$
  - Rewrite fit functions as  $g(M, \text{meanCorr}(m_{\text{true}}, X, \alpha), \text{sigma})$  where  $\text{meanCorr}$  is an (empirical) function that corrects for the bias depending on  $X$



# Coding the example problem

How do you code the preceding example problem

$$\text{PDF}(x,y) = \text{gauss}(x,m(y),s)$$

$$m(y) = m_0 + m_1 \cdot \text{sqrt}(y)$$

How do you do that? Just like that:

```
RooRealVar x("x","x",-10,10) ;
RooRealVar y("y","y",0,3) ;

// Build a parameterized mean variable for gauss
RooRealVar mean0("mean0","mean offset",0.5) ;
RooRealVar mean1("mean1","mean slope",3.0) ;
RooFormulaVar mean("mean","mean0+mean1*y",
                  RooArgList(mean0,mean1,y)) ;

RooRealVar sigma("sigma","width of gaussian",3) ;
RooGaussian gauss("gauss","gaussian",x,mean,sigma) ;
```

Build a function object  
 $m(y)=m_0+m_1 \cdot \text{sqrt}(y)$

Simply plug in  
function mean(y)  
where mean value  
is expected!

Plug-and-play parameters!

PDF expects a real-valued object  
as input, not necessarily a variable

# Generic real-valued functions

---

- **RooFormulaVar** makes use of the ROOT **TFormula** technology to build interpreted functions
  - Understands generic C++ expressions, operators etc
  - Two ways to reference RooFit objects  
By name:

```
RooFormulaVar f("f", "exp(foo)*sqrt(bar)", RooArgList(foo,bar)) ;
```

By position:

```
RooFormulaVar f("f", "exp(@0)*sqrt(@1)", RooArgList(foo,bar)) ;
```



- You can use **RooFormulaVar** where ever a 'real' variable is requested
- **RooPolyVar** is a compiled polynomial function

```
RooRealVar x("x", "x", 0., 1.) ;  
RooRealVar p0("p0", "p0", 5.0) ;  
RooRealVar p1("p1", "p1", -2.0) ;  
RooRealVar p2("p2", "p2", 3.0) ;  
RooFormulaVar f("f", "polynomial", x, RooArgList(p0, p1, p2)) ;
```

# What does the example p.d.f look like?

- Make 2D plot of p.d.f in  $(x,y)$

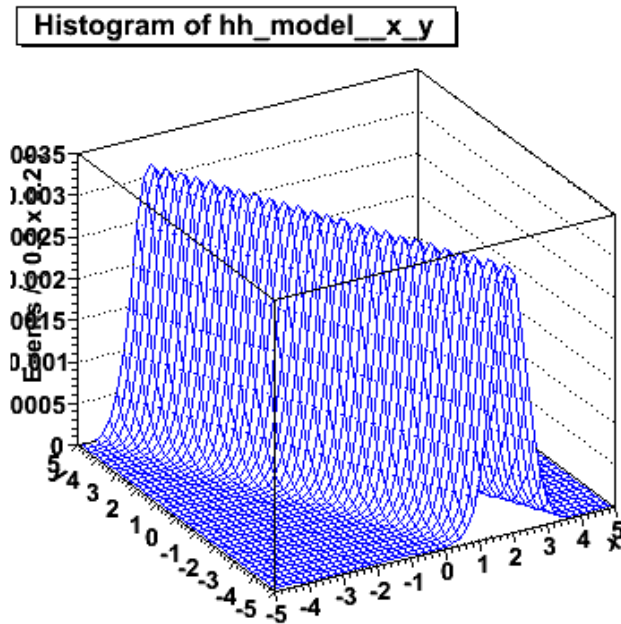

Projection on Y

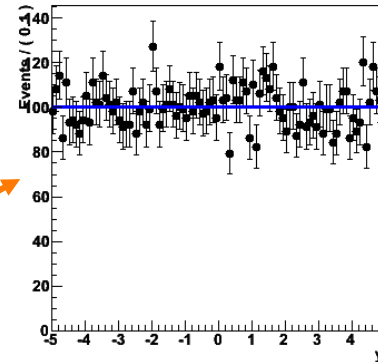

Projection on X

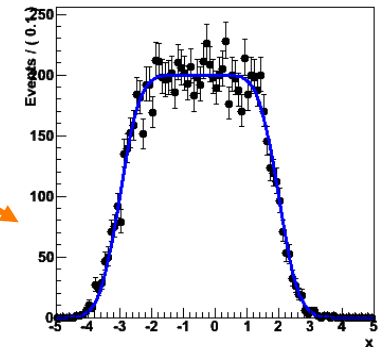

- Is the correct p.d.f for this problem?
  - Constructed a p.d.f with correct shape in  $x$ , given a value of  $y$  → OK
  - But p.d.f predicts flat distribution in  $y$  → Probably not OK
  - What we want is a pdf for  $X$  given  $Y$ , but without prediction on  $Y$  → Definition of a *conditional* p.d.f  $F(x|y)$

## Conditional p.d.f.s – Formulation and construction

---

- Mathematical formulation of a conditional p.d.f
  - A conditional p.d.f is not normalized w.r.t its conditional observables

$$F(\vec{x} | \vec{y}; \vec{p}) = \frac{f(\vec{x}, \vec{y}, \vec{p})}{\int f(\vec{x}, \vec{y}, \vec{p}) d\vec{x}}$$

- Note that denominator in above expression *depends on y* and is thus in general different for each event
- Constructing a conditional p.d.f in RooFit
  - Any RooFit p.d.f can be used as a conditional p.d.f as objects have no internal notion of distinction between parameters, observables and conditional observables
  - Observables that should be used as conditional observables have to be specified in use context (generation, plotting, fitting etc...)

## Using a conditional p.d.f – fitting and plotting

- For fitting, indicate in fitTo() call what the conditional observables are

```
pdf.fitTo(data, ConditionalObservables(y))
```

$$F(x|y) = \frac{f(x, y)}{\int f(x, y) d\bar{x}}$$

- You may notice a performance penalty if the normalization integral of the p.d.f needs to be calculated numerically.  
For a conditional p.d.f it must be evaluated again for each event

- Plotting: You cannot project a conditional  $F(x|y)$  on  $x$  without external information on the distribution of  $y$ 
  - Substitute integration with averaging over  $y$  values in data

Integrate over  $y$

$$P_p(x) = \frac{\int p(x, y) dy}{\int p(x, y) dx dy}$$



Sum over all  $y_i$  in dataset  $D$

$$P_p(x) = \frac{1}{N} \sum_{i=1, N}^D \frac{p(x, y_i)}{\int p(x, y_i) dx}$$

## Physics example with conditional p.d.f.s

---

- Want to fit **decay time distribution of B0 mesons** (exponential) convoluted with **Gaussian resolution**

$$F(t) = D(t; \tau) \otimes R(t, m, \sigma)$$

- However, **resolution** on decay time **varies from event by event** (e.g. more or less tracks available).
  - We have in the data an error estimate  $dt$  for each measurement from the decay vertex fitter (“*per-event error*”)
  - Incorporate this information into this physics model

$$F(t | \delta t) = D(t; \tau) \otimes R(t, m, \sigma \cdot \delta t)$$

- Resolution in physics model is adjusted for each event to expected error.
- Overall scale factor  $\sigma$  can account for incorrect vertex error estimates (i.e. if fitted  $\sigma > 1$  then  $dt$  was underestimate of true error)
- Physics p.d.f must use conditional p.d.f because it gives no sensible prediction on the distribution of the per-event errors

# Physics example with conditional p.d.f.s

- Some illustrations of decay model with per-event errors
  - Shape of  $F(t|\delta t)$  for several values of  $\delta t$

$$F(t | \delta t) = D(t; \tau) \otimes R(t, m, \sigma \cdot \delta t)$$

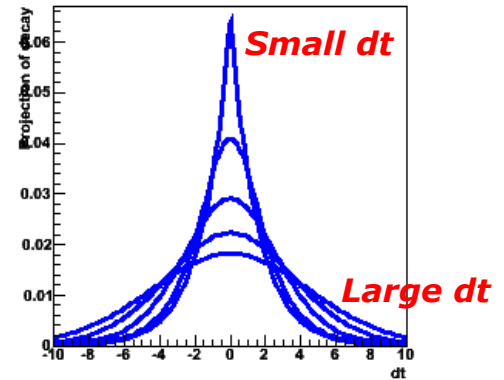

- Plot of  $D(t)$  and  $F(t|dt)$  projected over  $dt$

```
// Plotting of decay(t|dt_err)
RooPlot* frame = dt.frame() ;
data->plotOn(frame2) ;
decay_gm1.plotOn(frame2, ProjWData(*data)) ;
```

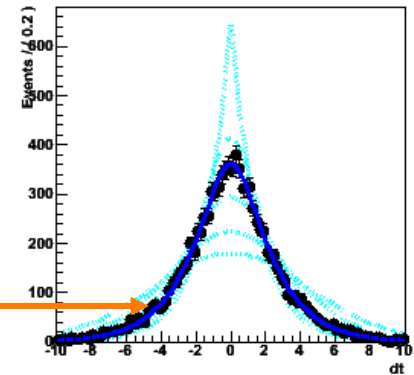

Note that projecting over large datasets can be slow. You can speed this up by projecting with a binned copy of the projection data

$$P_p(x) = \frac{1}{N} \sum_{i=1, N}^D \frac{p(x, y_i)}{\int p(x, y_i) dx}$$

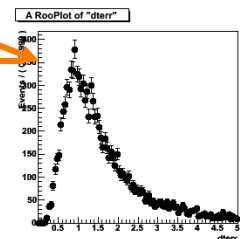

## How it works – event generation with conditional p.d.f.s

- Just like plotting, event generation of conditional p.d.f.s requires external input on the conditional observables
  - Given an external input dataset  $\mathbf{P}(dt)$
  - For each event in  $\mathbf{P}$ ,
    - set the value of  $dt$  in  $F(d|dt)$  to  $dt_i$
    - generate one event for observable  $t$  from  $F(t|dt_i)$
  - Store both  $t_i$  and  $dt_i$  in the output dataset

A RooPlot of "dterr"

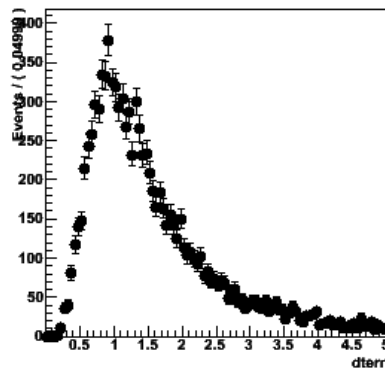

A RooPlot of "dt"

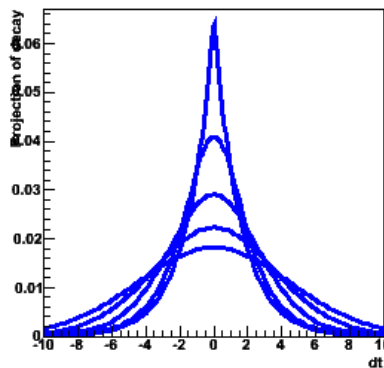

Histogram of data\_dt\_dterr

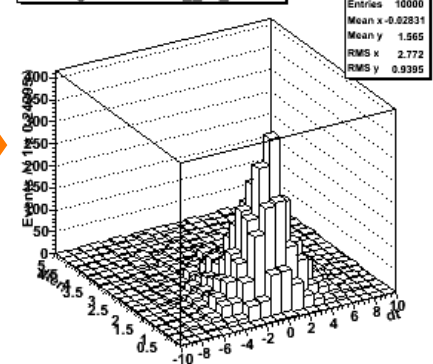



## Complete example of decay with per-event errors

---

```

RooRealVar dt("dt","dt",-10,10) ;
RooRealVar dterr("dterr","dterr",0.001,5) ;
RooRealVar tau("tau","tau",1.548) ;

// Build Gauss(dt,0,sigma*dterr)
RooRealVar sigma("sigma","sigma1",1) ;
RooGaussModel gm1("gm1","gauss model 1",dt,RooConst(0),sigma,dterr) ;

// Construct decay(t,tau) (x) gauss1(t,0,sigma*dterr)
RooDecay decay_gm1("decay_gm1","decay",dt,tau,gm1,RooDecay::DoubleSided) ;

// Toy MC generation of decay(t|dterr)
RooDataSet* toydata = decay_gm1.generate(dt,ProtoData(dterrData)) ;

// Fitting of decay(t|dterr)
decay_gm1.fitTo(*data,ConditionalObservables(dterr))

// Plotting of decay(t|dterr)
RooPlot* frame = dt.frame() ;
data->plotOn(frame2) ;
decay_gm1.plotOn(frame2,ProjWData(*data)) ;

```

# Model building – Products with conditional p.d.f.s

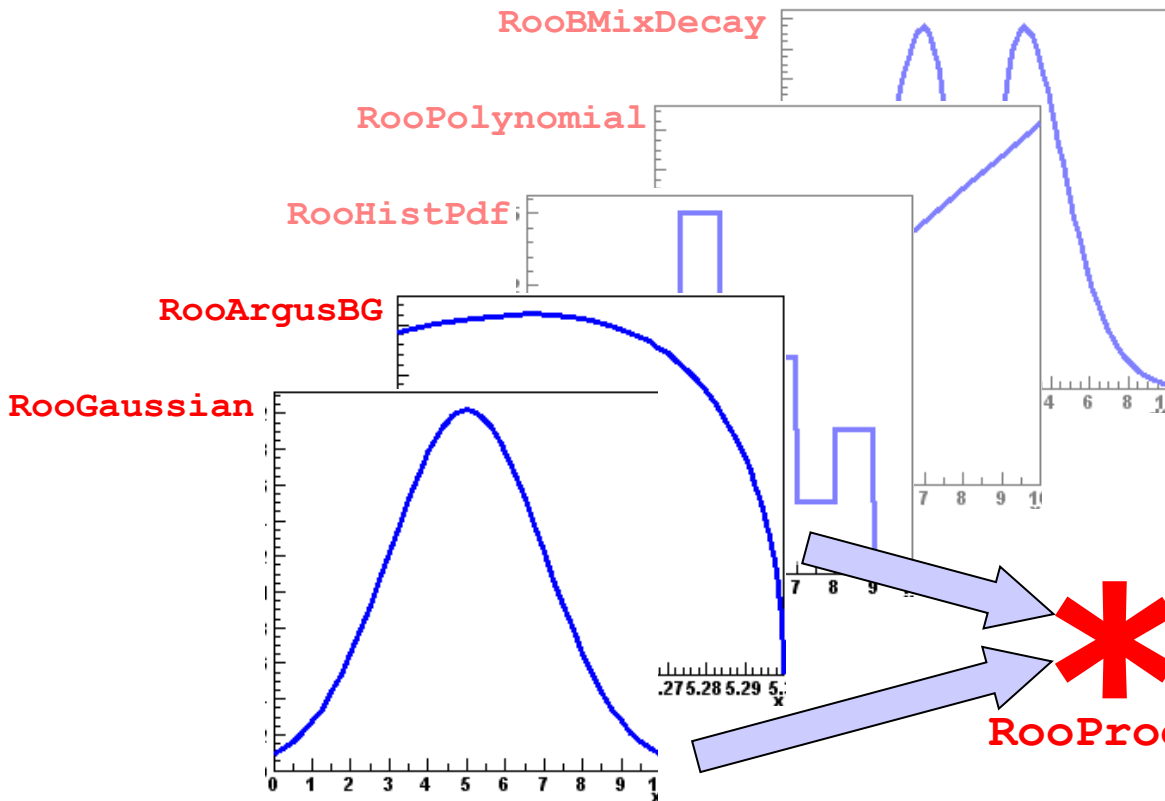

RooProdPdf k("k", "k", g,  
Conditional(f,x))  
 $K(x, y) = F(x | y) \cdot G(y)$

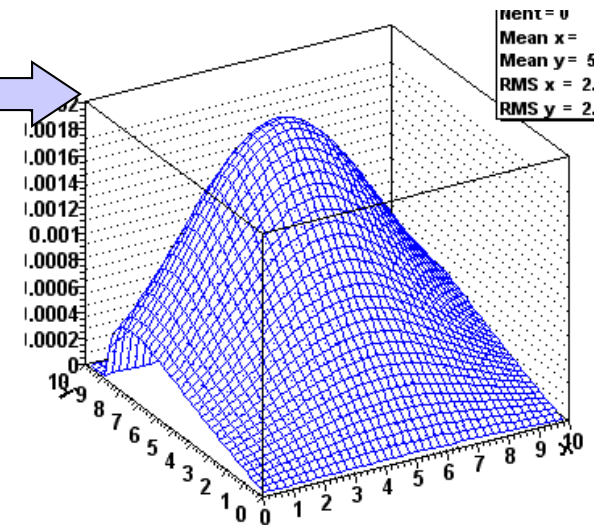

## Products with conditional p.d.f.s – Mathematical form

---

- Use of conditional p.d.f.s has some drawbacks
  - **Practical**: Somewhat unwieldy in use because external input needed e.g. in plotting and event generation steps
  - **Fundamental**: In composite conditional p.d.f.s

$$F(x | y) = f \cdot S(x | y) + (1 - f) \cdot B(x | y)$$

signal and background by construction always using the same distributions for conditional observables. This assumption may not be valid leading, to possible fit biases (Punzi physics/0401045)

- Can mitigate both problems by multiplying conditional p.d.f.s with a p.d.f. for the conditional observables so that product is not conditional
  - Can multiply with different p.d.f for signal and background

$$K(x, y) = F(x | y) \cdot G(y) = \frac{f(x, y)}{\int f(x, y) dx} \frac{g(y)}{\int g(y) dy}$$

## Normalization and event generation in conditional products

---

- Products of conditional and plain pdf's are self normalized
  - Proof is trivial

$$\iint K(x, y) = \iint \frac{f(x, y)}{\int f(x, y) dx} \frac{g(y)}{\int g(y) dy} dx dy = \left( \int \frac{f(x, y)}{\int f(x, y) dx} dx \right) \left( \int \frac{g(y)}{\int g(y) dy} dy \right) = 1 \cdot 1$$

- Generation of events from products of conditional and plain p.d.fs can be handling by handling generation of observables in order

$$F(x | y) \cdot G(y)$$

*First generate y, then x*

$$F(x | y) \cdot G(y | z) \cdot H(z)$$

*First generate z, then y, then x*

# Example with product of conditional and plain p.d.f.

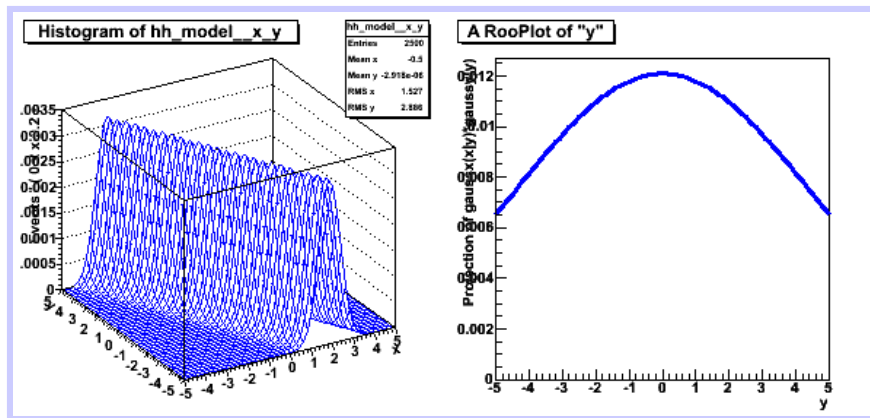

$$g_x(x|y) * g_y(y)$$

=

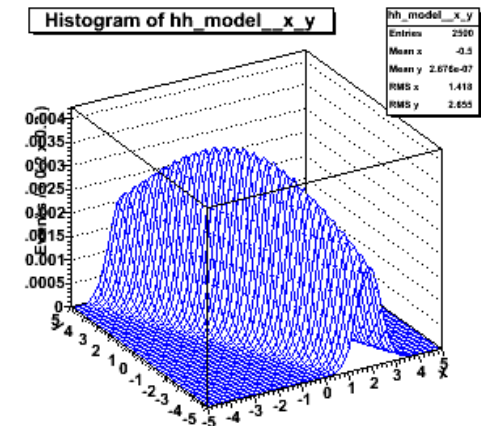

$$model(x,y)$$

```
// Create function f(y) = a0 + a1*y
RooPolyVar fy("fy","fy",y,RooArgSet(a0,a1)) ;

// Create gaussx(x,f(y),0.5)
RooGaussian gaussx("gaussx","gaussx",x,fy,sx) ;

// Create gausy(y,0,3)
RooGaussian gausy("gausy","Gaussian in y",y,my,sy) ;

// Create gaussx(x,sx|y) * gausy(y)
RooProdPdf model("model","gaussx(x|y)*gausy(y)",
    gausy,Conditional(gaussx,x)) ;
```

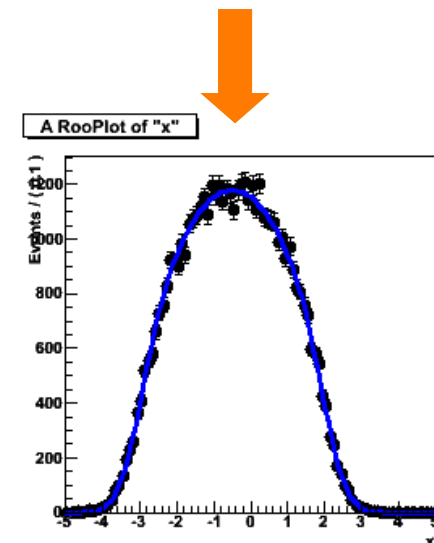

$$\int g_x(x|y)g(y)dy$$

# 5

## Managing data, discrete variables simultaneous fits

- *Binned, unbinned datasets*
- *Importing data*
- *Using discrete variable to classify data*
- *Simultaneous fits on multiple datasets*

# A bit more detail on RooFit datasets

- A dataset is a N-dimensional collection of points
  - With optional weights
  - No limit on number of dimensions
  - Observables continuous (`RooRealVar`) or discrete (`RooCategory`)
- Interface of each dataset is 'current' row
  - Set of RooFit value objects that represent coordinate of current event

(Internal ROOT *TTree*)

x	Y	wgt
1.0	6.6	1
3.5	11.1	1
2.7	2.2	1
5.2	1.1	1

Current coordinate return by `RooAbsData::get()`  
Current weight returned by `RooAbsData::weight()`

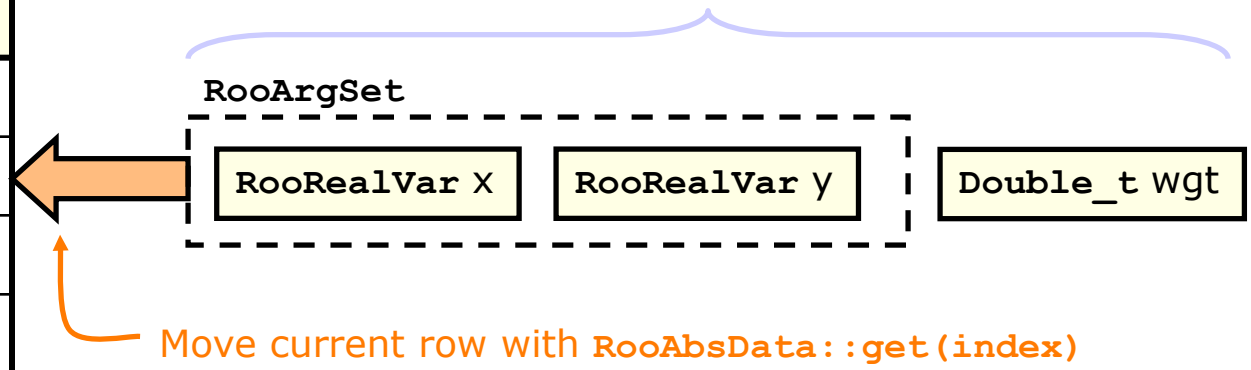

# Binned data, or unbinned data (with optional weights)

- Binned or unbinned ML fit?
  - In most RooFit applications it doesn't matter

Unbinned

x	y	z
1	3	5
2	4	6
1	3	5
2	4	6

Binned

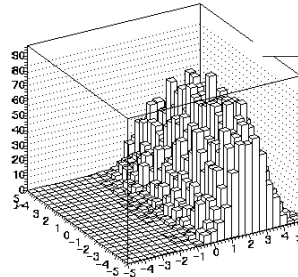

Internally binned data is represented the same way as unbinned data, A ROOT TTree with the bin coordinates

**RooDataSet**

**RooDataHist**

**RooAbsData**

- For example ML fitting interface takes abstract RooAbsData object
  - Binned data → Binned likelihood
  - Unbinned data → Unbinned likelihood
- Weights are supported in unbinned datasets
  - But use with care. Error analysis in ML fits to weighted unbinned data can be complicated!



# Importing unbinned data

---

- From ROOT trees
  - `RooRealVar` variables are imported from /D /F /I tree branches
  - `RooCategory` variables are imported from /I /b tree branches
  - **Mapping** between `TTree` branches and dataset variables **by name**:  
e.g. `RooRealVar x("x","x",-10,10)` imports `TTree` branch "x"

```
RooRealVar x("x","x",-10,10) ;  
RooRealVar c("c","c",0,30) ;  
RooDataSet data("data","data",inputTree,RooArgSet(x,c)) ;
```

- **Only events with 'valid' entries are imported.** In above example any events with  $|x|>10$  or  $c<0$  or  $c>30$  are *not* imported
- From ASCII files
  - One line per event, order of variables as given in `RooArgList`

```
RooDataSet* data =  
    RooDataSet::read("ascii.file",RooArgList(x,c)) ;
```

# Importing binned data

---

- From ROOT **THx** histogram objects

```
RooDataHist bdata1 ("bdata", "bdata", RooArgList (x), histo1d) ;  
RooDataHist bdata2 ("bdata", "bdata", RooArgList (x, y), histo2d) ;  
RooDataHist bdata3 ("bdata", "bdata", RooArgList (x, y, z), histo3d) ;
```

- From a **RooDataSet**

```
RooDataHist* binnedData = data->binnedClone () ;
```

# Extending and reducing **unbinned** datasets

- Appending

```
RooDataSet d1 ("d1", "d1", RooArgSet(x, y, z));  
RooDataSet d2 ("d2", "d2", RooArgSet(x, y, z));  
  
d1.append(d2);
```

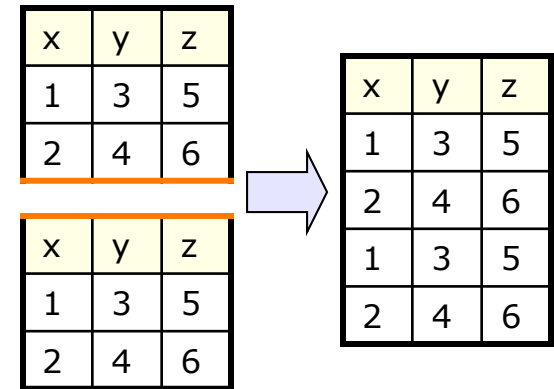

- Merging

```
RooDataSet d1 ("d1", "d1", RooArgSet(x, y));  
RooDataSet d2 ("d2", "d2", RooArgSet(z));  
  
d1.merge(d2);
```

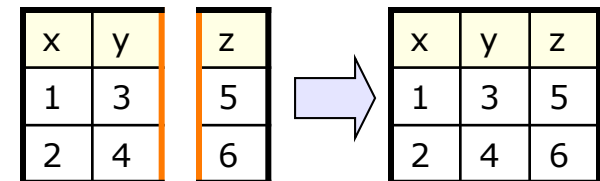

- Reducing

```
RooDataSet d1 ("d1", "d1", RooArgSet(x, y, z));  
RooDataSet* d2 = d1.reduce(RooArgSet(x, y));  
RooDataSet* d3 = d1.reduce("x>1");
```

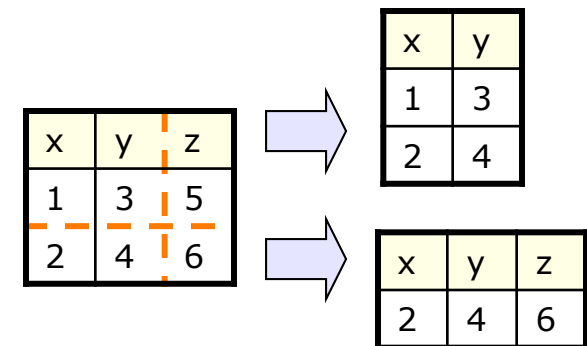

# Adding and reducing **binned** datasets

- Adding

```
RooDataHist d1 ("d1", "d1",  
               RooArgSet(x, y));  
RooDataHist d2 ("d2", "d2",  
               RooArgSet(x, y));  
  
d1.add(d2);
```

w	y1	y2
x1	0	1
x2	1	0

w	y1	y2
x1	0	1
x2	1	0



w	y1	y2
x1	1	1
x2	1	1

- Reducing

```
RooDataHist d1 ("d1", "d1",  
               RooArgSet(x, y));  
  
RooDataHist* d2 =  
    d1.reduce(x);  
  
RooDataHist* d3 =  
    d1.reduce("x>1");
```

w	y1	y2
x1	0	1
x2	1	0



-	w
x1	1
x2	1

w	y1	y2
x1	0	1
x2	1	0



w	y1	y2
x1	0	0
x2	1	0

# Datasets and discrete observables

---

- Discrete observables play an important role in management of datasets
  - Useful to classify 'sub datasets' inside datasets
  - Can collapse multiple, logically separate datasets into a single dataset by adding them and labeling the source with a discrete observable
  - Allows to express operations such a simultaneous fits as operation on a single dataset

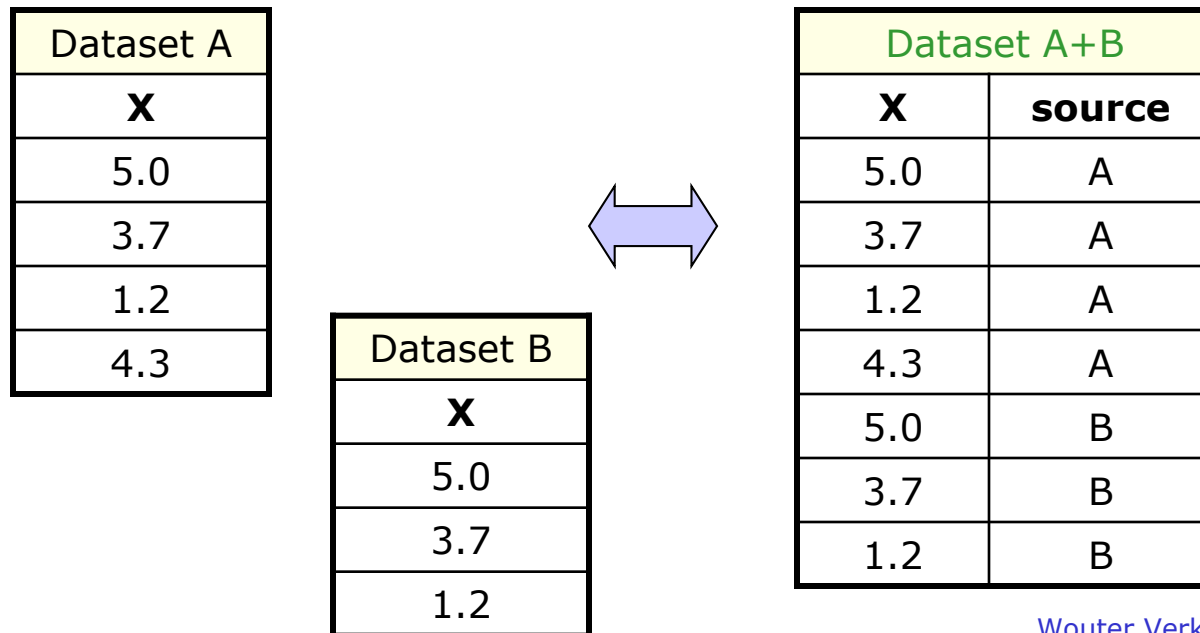

# Discrete variables in RooFit – RooCategory

- Properties of RooCategory variables
  - Finite set of named states → [self documenting](#)
  - Optional integer code associated with each state

At creation,  
a category  
has no states

Add states  
with a label *and* index

Add states  
with a label only.  
*Indices will be  
automatically  
assigned*

```
// Define a cat. with explicitly numbered states  
RooCategory b0flav("b0flav","B0 flavour") ;  
b0flav.defineType("B0",-1) ;  
b0flav.defineType("B0bar",1) ;  
  
// Define a category with labels only  
RooCategory tagCat("tagCat","Tagging technique") ;  
tagCat.defineType("Lepton") ;  
tagCat.defineType("Kaon") ;  
tagCat.defineType("NetTagger-1") ;  
tagCat.defineType("NetTagger-2") ;
```

- Used for classification of data, or to describe occasional discrete fundamental observable (e.g.  $B^0$  flavor)

## Datasets and discrete observables – part 2

- Example of appending datasets with label attachment

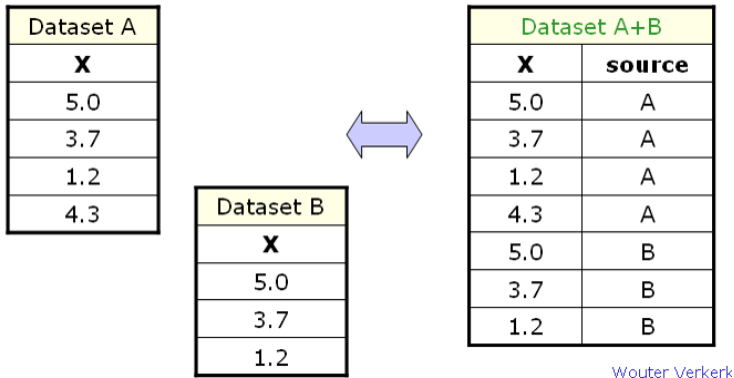

```
RooCategory c("c","source")
c.defineType("A") ;
c.defineType("B") ;

// Add column with source label
c.setLabel("A") ; dA->addColumn(c) ;
c.setLabel("B") ; dB->addColumn(c) ;

// Make combined dataset
RooDataSet* dAB = dA->Clone("dAB") ;
dAB->append(*dB) ;
```

- But can also derive classification from info within dataset
  - E.g. ( $10 < x < 20$  = "signal",  $0 < x < 10$  |  $20 < x < 30$  = "sideband")
  - Encode classification using real  $\rightarrow$  discrete mapping functions

# A universal real→discrete mapping function

- Class `RooThresholdCategory` maps ranges of input `RooRealVar` to states of a `RooCategory`

background      Sig      Sideband

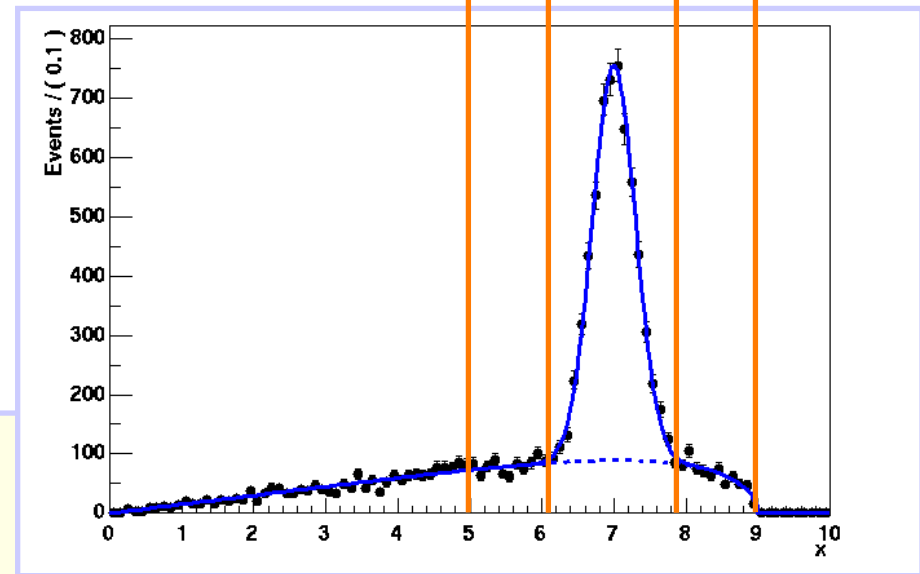

```
// Mass variable  
RooRealVar m("m", "mass, 0, 10.");
```

```
// Define threshold category  
RooThresholdCategory region("region", "Region of M", m, "Background");  
region.addThreshold(9.0, "SideBand");  
region.addThreshold(7.9, "Signal");  
region.addThreshold(6.1, "SideBand");  
region.addThreshold(5.0, "Background");
```

Define region boundaries

Default state



# Discrete → Discrete mapping function

- **RoMappedCategory** provides cat → cat mapping

Define input category

```
RoCategory tagCat("tagCat", "Tagging category") ;  
tagCat.defineType("Lepton") ;  
tagCat.defineType("Kaon") ;  
tagCat.defineType("NetTagger-1") ;  
tagCat.defineType("NetTagger-2") ;
```

Create mapped category

```
RoMappedCategory tagType("tagType", "type", tagCat) ;
```

```
tagType.map("Lepton", "CutBased") ;  
tagType.map("Kaon", "CutBased") ;  
tagType.map("NT*", "NeuralNet") ;
```

Add mapping rules

Wildcard expressions allowed

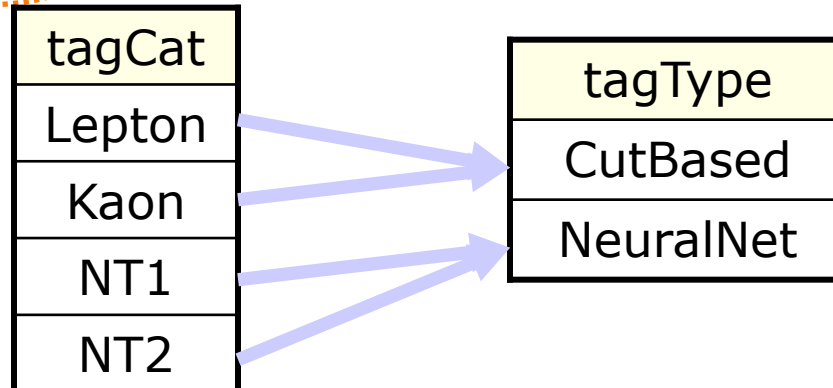

# Discrete multiplication function

- `RoosuperCategory/RooMultiCategory` provides category multiplication

```
// Define 'product' of tagCat and runBlock  
RoosuperCategory prod("prod", "prod", RooArgSet(tag, flav))
```

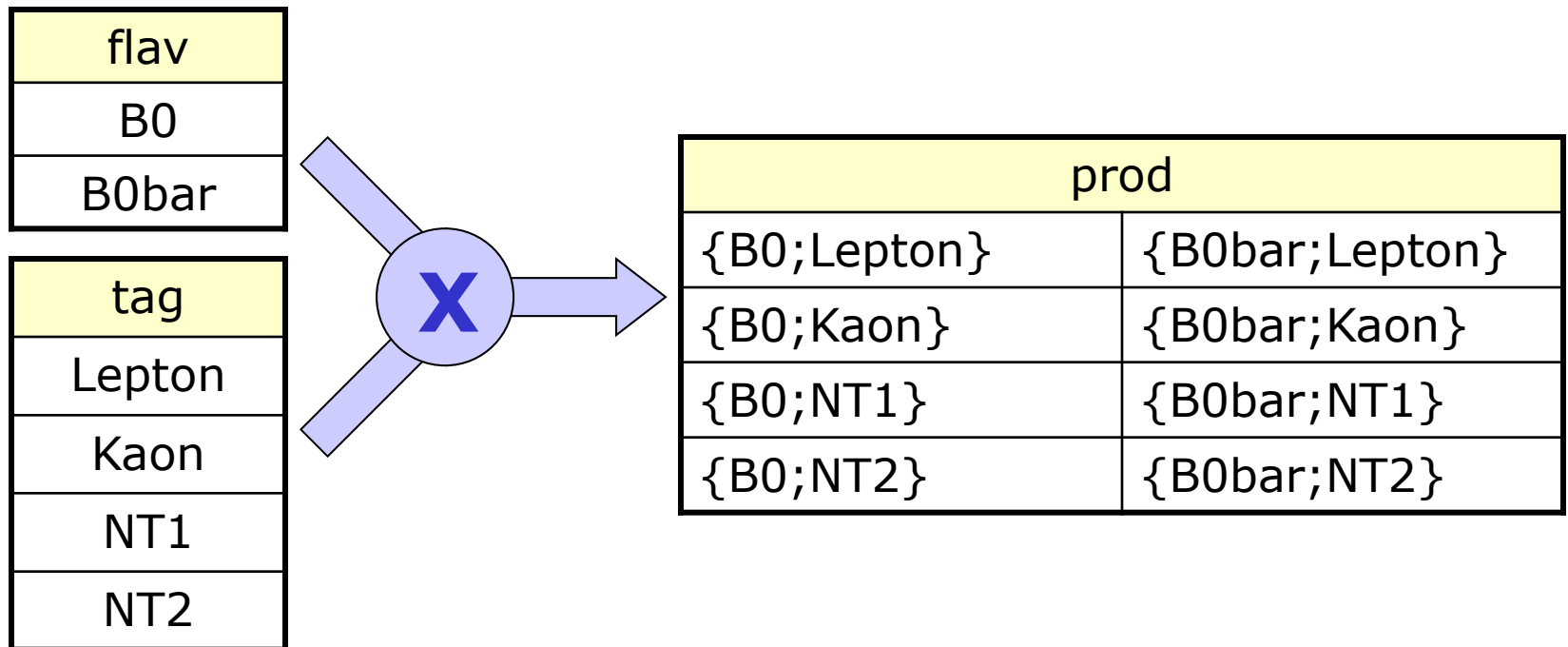

# Exploring discrete data

- Like real variables of a dataset can be plotted, discrete variables can be tabulated

Tabulate contents of dataset  
by category state

```
RootTable* table=data->table(b0flav) ;  
table->Print() ;
```

```
Table b0flav : aData  
+-----+-----+  
|      B0 | 4949 |  
| B0bar  | 5051 |  
+-----+-----+
```

Extract contents by label

```
Double_t nB0 = table->get("B0") ;
```

Extract contents fraction by label

```
Double_t b0Frac = table->getFrac("B0") ;
```

```
data->table(tagCat, "x>8.23")->Print() ;
```

Tabulate contents of  
selected part of dataset

```
Table tagCat : aData(x>8.23)  
+-----+-----+  
|      Lepton | 668 |  
|      Kaon   | 717 |  
| NetTagger-1 | 632 |  
| NetTagger-2 | 616 |  
+-----+-----+
```

# Exploring discrete data

- *Discrete functions*, built from categories in a dataset can be tabulated likewise

Tabulate `RoosuperCategory` states

```
data->table(b0Xtcat) ->Print() ;
```

```
Table b0Xtcat : aData
```

+-----+-----+	
{B0;Lepton}	1226
{B0bar;Lepton}	1306
{B0;Kaon}	1287
{B0bar;Kaon}	1270
{B0;NetTagger-1}	1213
{B0bar;NetTagger-1}	1261
{B0;NetTagger-2}	1223
{B0bar;NetTagger-2}	1214
+-----+-----+	

Tabulate `RoMappedCategory` states

```
data->table(tcatType) ->Print() ;
```

```
Table tcatType : aData
```

+-----+-----+	
Unknown	0
Cut based	5089
Neural Network	4911
+-----+-----+	

# Fitting multiple datasets simultaneously

- Simultaneous fitting efficient solution to incorporate information from control sample into signal sample
- Example problem: search rare decay
  - Signal dataset has small number entries.

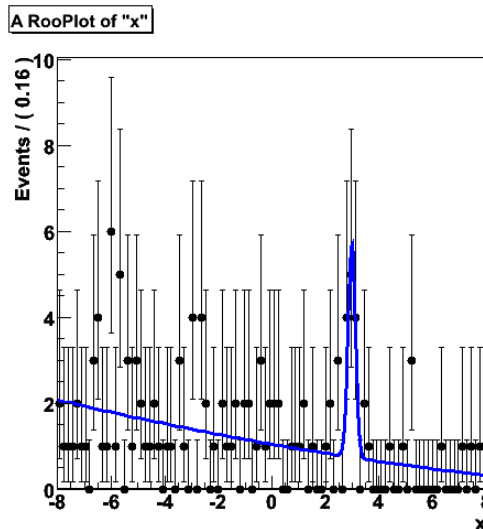

Par	FinalValue	+/-	Error
----	-----	-----	-----
a0	-1.0544e-01	+/-	2.88e-02
a1	2.2698e-03	+/-	4.92e-03
nbkg	1.0933e+02	+/-	1.07e+01
<b>nsig</b>	<b>1.0680e+01</b>	<b>+/-</b>	<b>3.92e+00</b>
mean	2.9787e+00	+/-	6.25e-02
width	1.3764e-01	+/-	6.29e-02

- Statistical uncertainty on shape in fit contributes significantly to uncertainty on fitted number of signal events
- However can constrain shape of signal from control sample (e.g. another decay with similar properties that is not rare), so no need to rely on simulations

# Fitting multiple datasets simultaneously

- Fit to control sample yields accurate information on shape of signal

A RooPlot of "x"

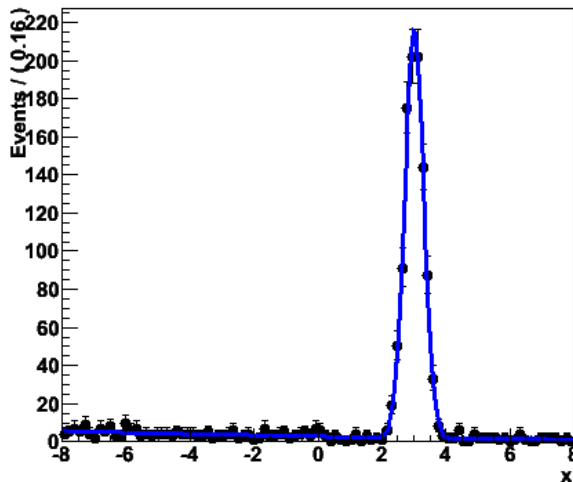

Par	FinalValue	+/-	Error
----	-----	-----	-----
a0	-9.9212e-02	+/-	1.75e-02
a1	3.3116e-03	+/-	3.57e-03
nbkg	3.0406e+02	+/-	1.83e+01
nsig	9.9594e+02	+/-	3.21e+01
m	3.0098e+00	+/-	9.83e-03
s	2.9891e-01	+/-	7.39e-03

- Q: What is the most practical way to combine shape measurement on control sample to measurement of signal on physics sample of interest
- A: Perform a **simultaneous** fit
  - Automatic propagation of errors & correlations
  - Combined measurement (i.e. error will reflect contributions from both physics sample and control sample)

# Discrete observable as data subset classifier

- Likelihood level definition of a simultaneous fit

$$-\log(L) = \sum_{i=1,n} -\log(PDF_A(D_A^i)) + \sum_{i=1,m} -\log(PDF_B(D_B^i))$$

- PDF level definition of a simultaneous fit

$$-\log(L) = \sum_{i=1,n} -\log(simPDF(D_{A+B}^i))$$

RooSimultaneous  
implements 'switch' PDF:

```
case (indexCat) {  
  A: return pdfA ;  
  B: return pdfB ;  
}
```

Likelihood of `switchPdf`  
with `composite dataset`  
*automatically* constructs  
sum of likelihoods above

Dataset A+B	
X	source
5.0	A
3.7	A
1.2	A
4.3	A
5.0	B
3.7	B
1.2	B

# Using RooSimultaneous to implement preceding example

Fit to signal data

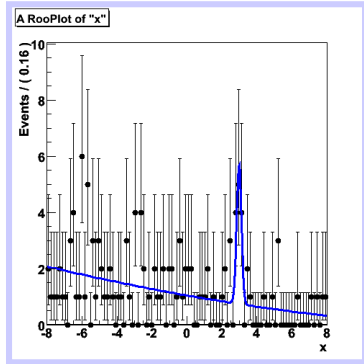

```
RooCategory c("c","c") ;  
c.defineType("control") ;  
c.defineType("physics") ;
```

```
RooSimultaneous sim_model("sim_model","",c) ;  
sim_model.addPdf(model_phys,"physics") ;  
sim_model.addPdf(model_ctrl,"control") ;
```

```
sim_model.fitTo(*d,Extended()) ;
```

Combined fit

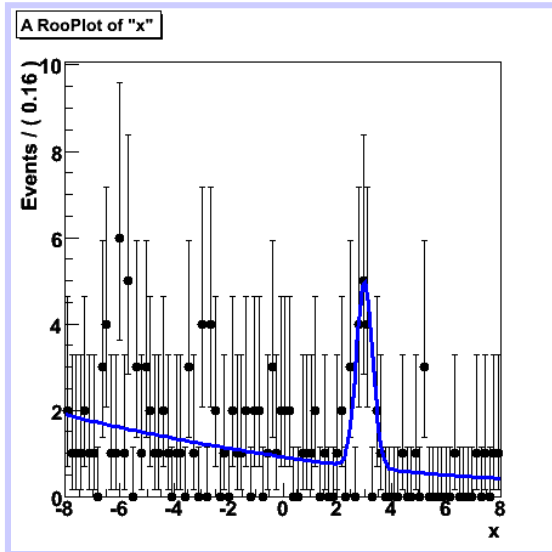

Signal shape  
constrained  
from control  
sample

Parameter	FinalValue	+/-	Error
-----	-----	-----	-----
a0_ctrl	-8.0947e-02	+/-	1.47e-02
a0_phys	-1.1825e-01	+/-	3.26e-02
a1_ctrl	2.1004e-04	+/-	3.12e-03
a1_phys	4.2259e-03	+/-	5.55e-03
nbkg_ctrl	3.1054e+02	+/-	1.86e+01
nbkg_phys	1.0633e+02	+/-	1.06e+01
nsig_ctrl	9.8946e+02	+/-	3.20e+01
<b>nsig_phys</b>	<b>1.3647e+01</b>	<b>+/-</b>	<b>4.44e+00</b>
m	2.9983e+00	+/-	9.69e-03
s	2.9255e-01	+/-	7.53e-03

Relative error on Nsig  
improved from 37% to 32%



## Other scenarios in which simultaneous fits are useful

---

- Preceding example was 'asymmetric'
  - Very large control sample, small signal sample
  - Physics in each channel possibly different (but with some similar properties)
- There are also 'symmetric' use cases
  - Fit multiple data sets that are functionally equivalent, but have slightly different properties (e.g. purity)
  - Example: Split B physics data in block separated by flavor tagging technique (each technique results in a different sensitivity to CP physics parameters of interest).
  - Split data in block by data taking run, mass resolutions in each run may be slightly different
  - For symmetric use cases pdf-level definition of simultaneous fit very convenient as you usually start with a single dataset with subclassing formation derived from its observables
- By splitting data into subsamples with p.d.f.s that can be tuned to describe the (slightly) varying properties you can increase the statistical sensitivity of your measurement

# A more empirical approach to simultaneous fits

- Instead of investing a lot of time in developing multi-dimensional models → Split data in many subsamples, fit all subsamples simultaneously to slight variations of 'master' p.d.f
- Example: Given dataset  $D(x,y)$  where observable of interest is  $x$ .
  - Distribution of  $x$  varies slightly with  $y$
  - Suppose we're only interested in the width of the peak which is supposed to be invariant under  $y$  (unlike mean)
  - Slice data in 10 bins of  $y$  and simultaneous fit each bin with p.d.f that only has different Gaussian mean parameter, but same width

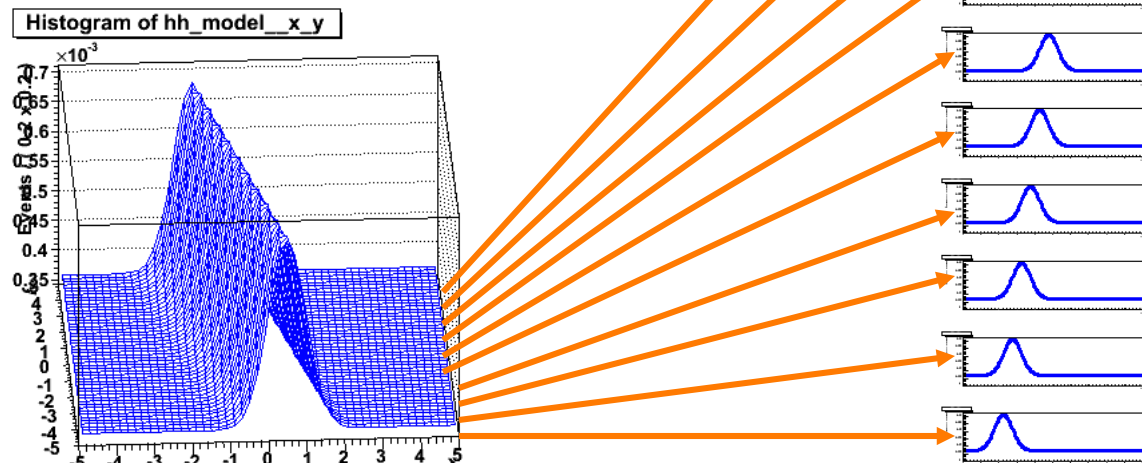

# A more empirical approach to simultaneous fits

- Fit to sample of preceding page would look like this
  - Each mean is fitted to expected value ( $-4.5 + \text{ibin}$ )

Floating Parameter	FinalValue +/-	Error
mean_bin1	-4.5302e+00 +/-	1.62e-02
mean_bin2	-3.4928e+00 +/-	1.38e-02
mean_bin3	-2.4790e+00 +/-	1.35e-02
mean_bin4	-1.4174e+00 +/-	9.64e-03
mean_bin5	-4.8945e-01 +/-	7.95e-03
mean_bin6	4.0716e-01 +/-	9.67e-03
mean_bin7	1.4733e+00 +/-	1.37e-02
mean_bin8	2.4912e+00 +/-	1.44e-02
mean_bin9	3.5028e+00 +/-	1.41e-02
mean_bin10	4.5474e+00 +/-	1.68e-02
<b>sigma</b>	<b>2.7319e-01 +/-</b>	<b>2.46e-03</b>

- But joint measurement of sigma
- NB: Correlation matrix is mostly diagonal as all mean\_binXX parameters are completely uncorrelated!

# A more empirical approach to simultaneous fits

---

- Preceding example was somewhat silly for illustrational clarity, but more sensible use cases exist
  - Example: **Measurement CP violation in B decay**. Analyzing power of each event is diluted by factor  $(1-2w)$  where  $w$  is the mistake rate of the flavor tagging algorithm
  - Neural net flavor tagging algorithm provides a tagging probability for each event in data. Could use  $\text{prob}(\text{NN})$  as  $w$ , but then we rely on good calibration of NN, don't want that
  - Do simultaneous fit to CPV+Mixing samples, can measure  $w$  from the latter. Now not relying on NN calibration, but not exploiting event-by-event variation in analysis power.
  - Now divide (CPV+mixing) data in 10 or 20 subsets corresponding to bins in  $\text{prob}(\text{NN})$ . Use identical p.d.f but only have separate parameter to express fitted mistag rate  $w_{\text{binXX}}$ .
  - Simultaneous fit will now exploit difference in analyzing power of events and be insensitive to calibration of flavor tagging NN.
  - If calibration of NN was OK fitting mistag rate in each bin of  $\text{prob}(\text{NN})$  will be average  $\text{prob}(\text{NN})$  value for that bin

# A more empirical approach to simultaneous fits

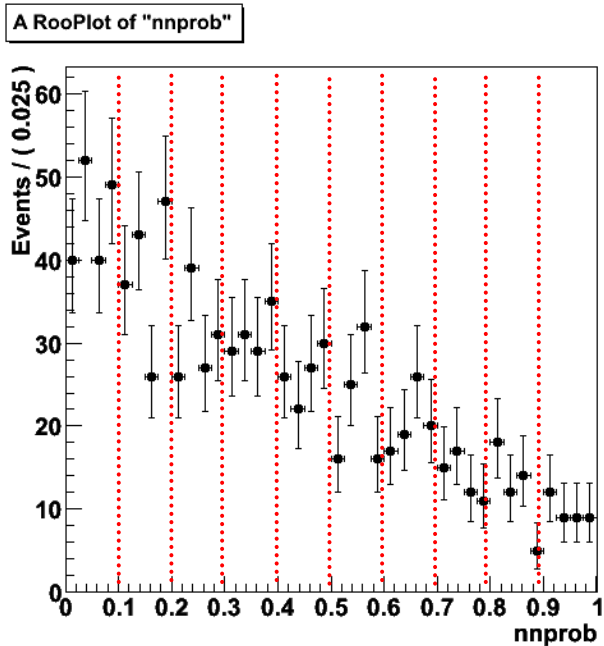

*Event with little analyzing power*

*Event with great analyzing power*

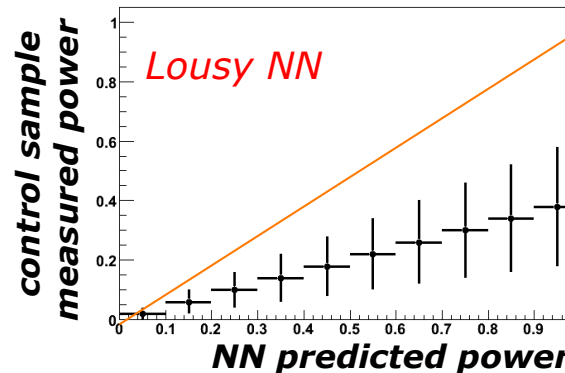
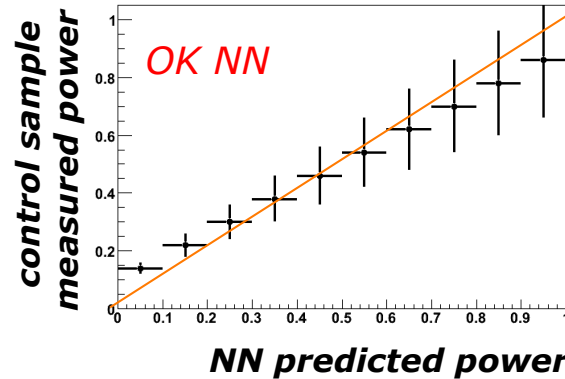
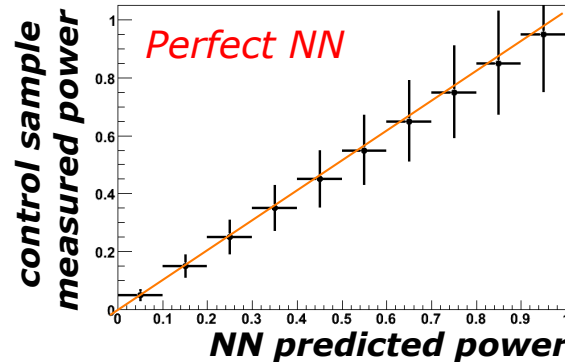

*Better precision on CPV meas. because more sensitive events in sample*

*In all 3 cases fit not biased by NN calibration*

*Worse precision on CPV meas. because less sensitive events in sample*

# How to replicate and customize p.d.f – Cumbersome by hand...

x	type
0.73	A
0.42	A
0.33	A
1.52	B
0.29	B
0.98	B
0.54	B

$$f_A * G(x; m, s_A) + (1 - f_A) * A(x; a, c)$$

$$f_B * G(x; m, s_B) + (1 - f_B) * A(x; a, c)$$

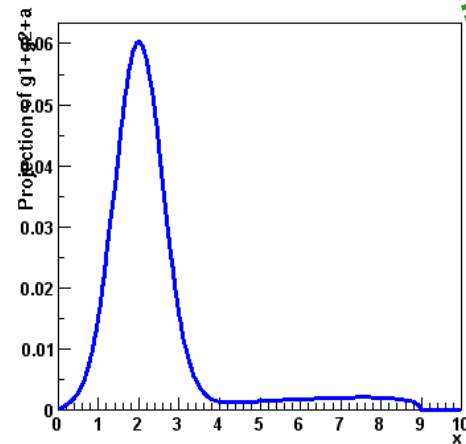
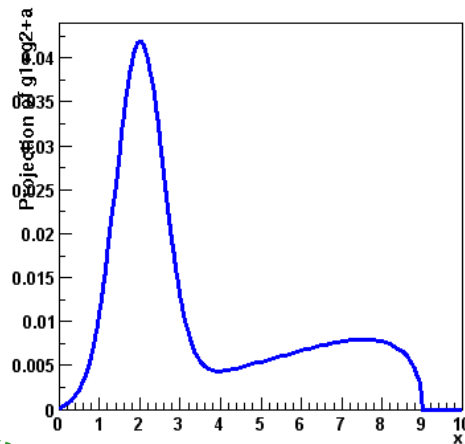

```

RooRealVar m("m","mean of gaussian",-10,10) ;
RooRealVar s_A("s_A","sigma of gaussian A",0,20) ;
RooGaussian gauss_A("gauss_A","gaussian A",X,m,s_A) ;
RooRealVar s_B("s_B","sigma of gaussian B",0,20) ;
RooGaussian gauss_B("gauss_B","gaussian B",X,m,s_B) ;

RooRealVar k ("k","ArgusBG kappa parameter",-50,0) ;
RooRealVar xm("xm","ArgusBG cutoff point",5.29) ;
RooArgusBG argus ("argus","argus background",X,k,xm) ;

RooRealVar f_A("f_A","fraction of gaussian A",0.,1.) ;
RooAddPdf pdf_A("pdf_A","gauss_A+argus",RooArgList(gauss_A,argus_A),f_A) ;
RooRealVar f_B("f_B","fraction of gaussian B",0.,1.) ;
RooAddPdf pdf_B("pdf_B","gauss_B+argus",RooArgList(gauss_B,argus_B),f_B) ;

RooSimultaneous simPdf("simPdf","simPdf",type) ;
simPdf.addPdf(pdf_A,"A") ;
simPdf.addPdf(pdf_B,"B") ;
    
```

# Automated p.d.f replication and customization

---

- A special tool **RooSimWSTool** exists to
  - Replicate existing p.d.f.s with customizations for each replication
  - Build a **RooSimultaneous** from all customized replicas
  - ..from a simple prescription

```
// Given categories run(run1,run2a,run2b) and tag(lep,kao,nn1,nn2)
// Import categories and prototype pdf into a workspace
RooWorkspace w("w","w") ;
w.import(RooArgSet(model,tag,run) ;

// Attach sim builder tool to workspace
RooSimWSTool sct(w) ;
RooSimultaneous* sim = sct.build("sim_model","model",
                                SplitParam("m,s","tag"),
                                SplitParam("a","run"),
                                SplitParam("b","run,tag")) ;
```

# Example of sin2b fit configuration from BaBar

- Start with three master p.d.f, one for Bmixing, two for BCPdecay (KL / KS)
- ASCII-filed splitting prescription

```
physModels = physCat      : Gold=CPGold BMix=BMixing
                               KlEmcE=KLong KlEmcM=KLong KlIfrE=KLong KlIfrM=KLong

BMixing = tagCat          : sig_eta,sig_deta,bgC_eta,bgL_eta,
                               bgP_eta,sigC_bias,outl_bias
        physCat,tagCat    : bgP_f,mbMean,mbWidth,argPar,sigfrac
        physCat           : bgC_f

CPGold = tagCat           : sig_eta,sig_deta,sigC_bias,outl_bias
        physCat           : mbMean,mbWidth,argPar,bgP_f,bgC_f
        physCat,tagCat    : sigfrac

KLong = tagCat            : sig_eta,sig_deta,sigC_bias,outl_bias
        physCat,tagCatL   : klSig_frac,klBgCck_frac,klKstBg_frac,klKshBg_frac,
                               klNPLBg_frac,klNPPBg_frac,klPsxBg_frac
        physCat           : deGMeanSig,deGWidthSig,deACutoffSig,deAKappaSig,
                               deGFracSig,dePol1IPbg,dePol2IPbg,dePol3IPbg,dePol4IPbg,
                               deACutoffSBbg,deAKappaSBbg,deGMeanKSBg,deGWidthKSBg,
                               deACutoffKSBg,deAKappaKSBg,deGFracKSBg,deG2MeanSig,
                               deG2WidthSig,deG2FracSig,psix_cpev
```

- Configure **RooSimWSTool**, build and ready!



# 6 Likelihood calculation & minimization

- *Details on the likelihood calculation*
- *Using MINUIT and RooMinuit*
- *Profile likelihoods*

# Fitting and likelihood minimization

---

- What happens when you do `pdf->fitTo(*data)`
  - 1) Construct object representing  $-\log$  of (extended) likelihood
  - 2) Minimize likelihood w.r.t floating parameters using MINUIT
- Can also do these two steps explicitly by hand

```
// Construct function object representing  $-\log(L)$ 
RoNLLVar nll("nll","nll",pdf,data) ;

// Minimize nll w.r.t its parameters
RoMinuit m(nll) ;
m.migrad() ;
m.hesse() ;
```

# Constructing the likelihood function

- Class `RooNLLVar` works universally for all p.d.f.s and all types of data
  - Binned data → Binned likelihood
  - Unbinned data → Unbinned likelihood
- Can add named arguments to constructor to control details of likelihood definition and mode of calculation

```
RooNLLVar nll("nll","nll",pdf,data,Extended()) ;
```

- Works like a regular RooFit function object, i.e. can retrieve value and make plots as usual

```
Double_t val = nll.getVal() ;  
RooArgSet* vars = nll.getVariables()  
  
RooPlot* frame = p.frame() ;  
nll.plotOn(frame) ;
```

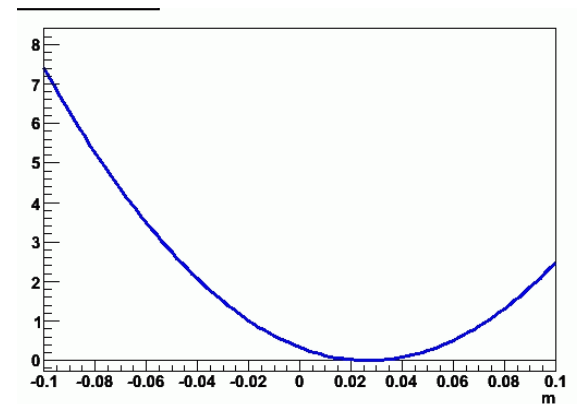

# Constructing the likelihood function

---

- All of the following RooNLLVar options are available under identical name in `pdf->fitTo()`
- Definition options
  - `Extended()` – Add extended likelihood term with  $N_{\text{exp}}$  taken from p.d.f and  $N_{\text{obs}}$  taken from data
  - `ConditionalObservable(obs)` – Treat given observables of pdf as conditional observables
- Mode of calculation options
  - `Verbose()` – Additional information is printed on how the likelihood calculation is set up
  - `NumCPU(N)` – Parallelize calculation of likelihood over N processes. Nice if you have a dual-quad core box (actual speedup is about factor 7.6 for N=8)

# Constructing the likelihood function

- Range options

- `Range("name")` – Restrict likelihood to events in dataset that are within given named range definition. Note that if a `Range()` is fitted, all `RooAddPdf` components will keep their fraction coefficient interpretation in the full domain of the observables (unless they have a prior fixed definition)

*This is default*

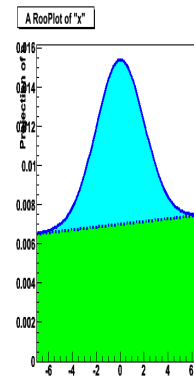
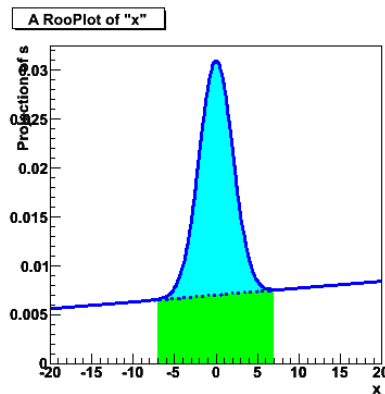

*With  
`SumCoefRange("name")`  
as well*

- `SumCoefRange("name")` – Instruct all `RooAddPdf` component of the p.d.f to interpret their fraction coefficients in the given range. Particularly useful in conjunction with `Range()`
- `SplitRange("name")` – For use with simultaneous p.d.f.s. If given name of range applied will be "`name_state`" where state is the name of the index category of the top level `RooSimultaneous`

# Constructing a $\chi^2$ function

---

- Along similar lines it is also possible to construct a  $\chi^2$  function
  - Only takes binned datasets (class `RooDataHist`)
  - Normalized p.d.f is multiplied by Ndata to obtain  $\chi^2$

```
// Construct function object representing -log(L)
RooNLLVar chi2("chi2","chi2",pdf,data) ;

// Minimize nll w.r.t its parameters
RooMinuit m(chi2) ;
m.migrad() ;
m.hesse() ;
```

- MINUIT error definition for  $\chi^2$  automatically adjusted to 1 (it is 0.5 for likelihoods) as default error level is supplied through virtual method of function base class `RooAbsReal`

## Automatic optimizations in the calculation of the likelihood

---

- Several automatic computational optimizations are applied the calculation of likelihoods inside RooNLLVar
  - **Components** that have **all constant** parameters are **pre-calculated**
  - Dataset variables not used by the PDF are dropped
  - **PDF normalization integrals are only recalculated when the ranges of their observables or the value of their parameters are changed**
  - **Simultaneous fits: When a parameters changes only parts of the total likelihood that depend on that parameter are recalculated**
    - Lazy evaluation: calculation only done when intergal value is requested
- Applicability of optimization techniques is re-evaluated for each use
  - Maximum benefit for each use case
- 'Typical' large-scale fits see significant speed increase
  - Factor of 3x – 10x not uncommon.

# Features of class RooMinuit

---

- Class `RooMinuit` is an *interface* to the ROOT implementation of the **MINUIT minimization** and error analysis package.
- `RooMinuit` takes care of
  - Passing value of minimized RooFit function to MINUIT
  - Propagated changes in parameters both from `RooRealVar` to MINUIT and back from MINUIT to `RooRealVar`, i.e. it keeps the state of RooFit objects synchronous with the MINUIT internal state
  - Propagate error analysis information back to `RooRealVar` parameters objects
  - Exposing high-level MINUIT operations to RooFit uses (MIGRAD,HESSE,MINOS) etc...
  - Making optional snapshots of complete MINUIT information (e.g. convergence state, full error matrix etc)



# A brief description of MINUIT functionality

---

- MIGRAD

- **Find function minimum.** Calculates function gradient, follow to (local) minimum, recalculate gradient, iterate until minimum found
  - To see what MIGRAD does, it is very instructive to do `RooMinuit::setVerbose(1)`. It will print a line for each step through parameter space
- Number of function calls required depends greatly on number of floating parameters, distance from function minimum and shape of function

- HESSE

- **Calculation of error matrix from 2<sup>nd</sup> derivatives at minimum**
- Gives symmetric error. Valid in assumption that likelihood is (locally parabolic)

$$\hat{\sigma}(p)^2 = \hat{V}(p) = \left( \frac{d^2 \ln L}{d^2 p} \right)^{-1}$$

- Requires roughly  $N^2$  likelihood evaluations (with  $N$  = number of floating parameters)

# A brief description of MINUIT functionality

---

- MINOS

- Calculate errors by explicit finding points (or contour for  $>1D$ ) where  $\Delta\text{-log}(L)=0.5$
- Reported errors can be asymmetric
- Can be very expensive in with large number of floating parameters

- CONTOUR

- Find contours of equal  $\Delta\text{-log}(L)$  in two parameters and draw corresponding shape
- Mostly an interactive analysis tool

## Note of MIGRAD function minimization

- For all but the most trivial scenarios **it is not possible to automatically find reasonable starting values of parameters**
  - So you need to supply 'reasonable' starting values for your parameters

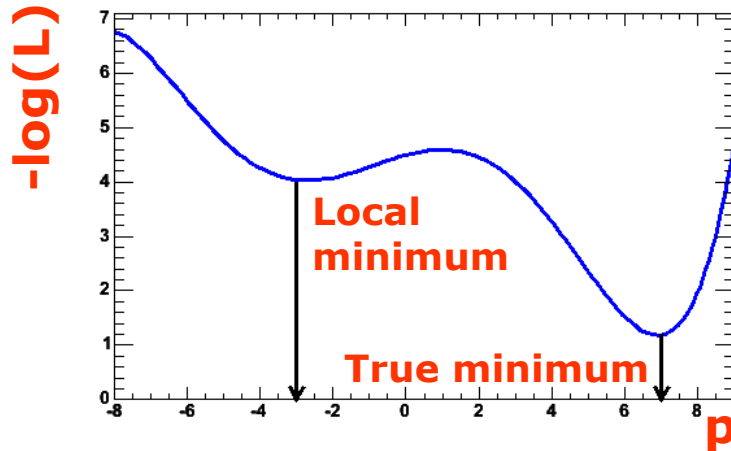

Reason: There may exist multiple (local) minima in the likelihood or  $\chi^2$

- You may also need to supply 'reasonable' initial step size in parameters. (A step size 10x the range of the above plot is clearly unhelpful)
- Using RooMinuit, the initial step size is the value of `RooRealVar::getError()`, so you can control this by supplying initial error values

## Illustration of difference between HESSE and MINOS errors

- 'Pathological' example likelihood with multiple minima and non-parabolic behavior

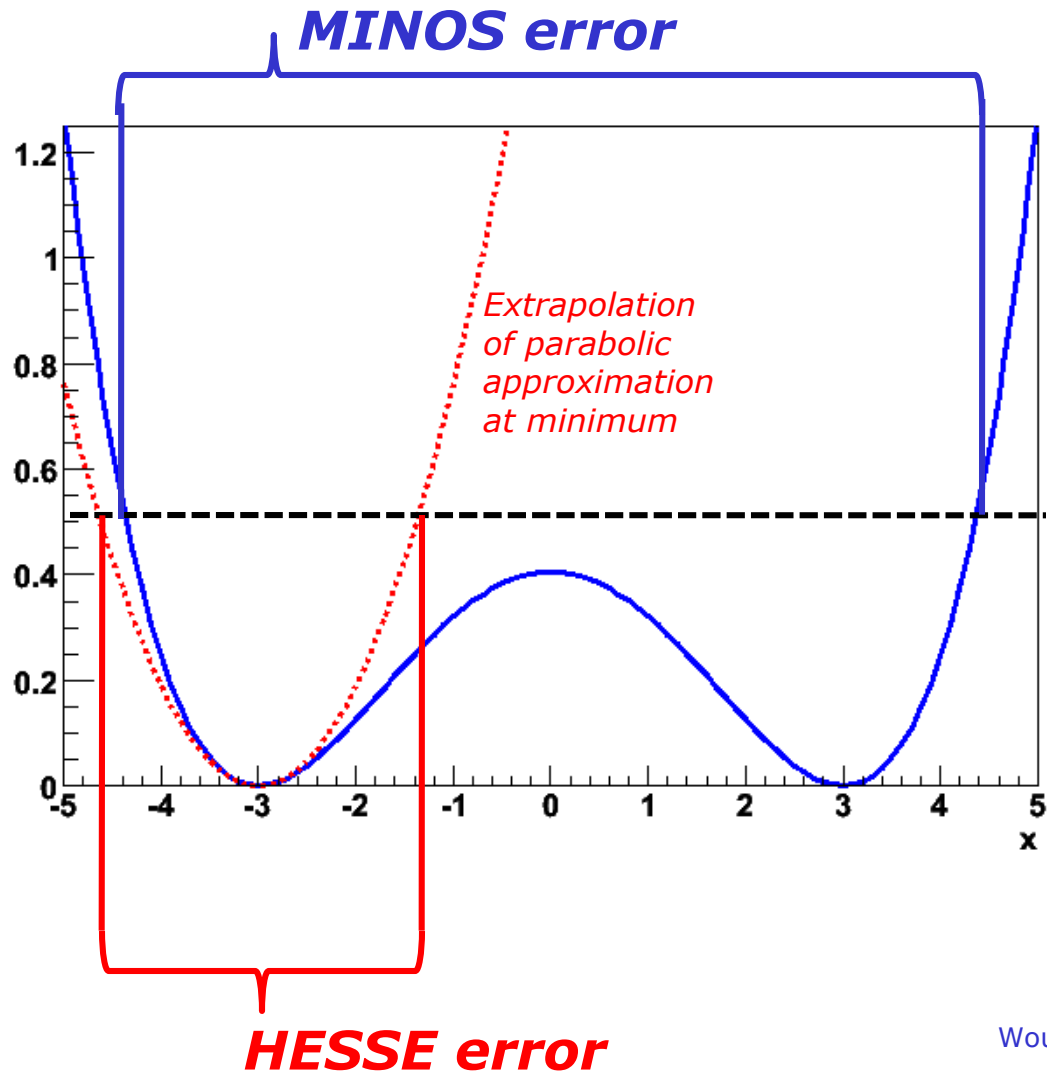

## Illustration of MINOS errors in 2 dimensions

- Now we have a contour of  $\Delta n_{ll}$  instead of two points
- MINOS errors on  $p_x, p_y$  now defined by box enclosing contour

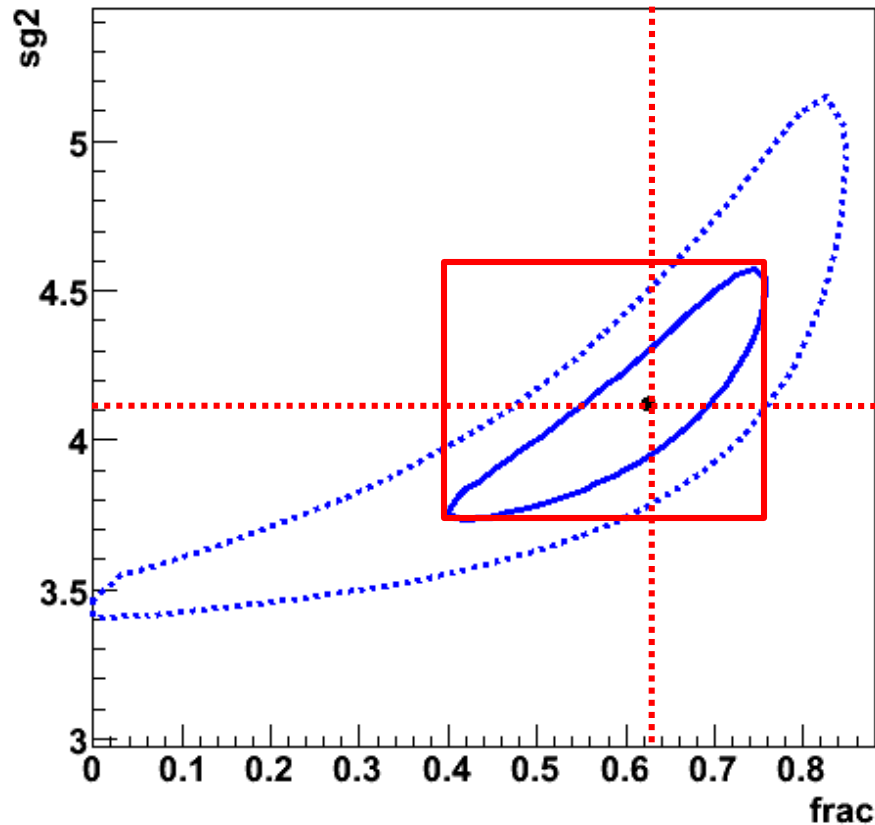

# Demonstration of RooMinuit use

---

```
// Start Minuit session on above nll
RooMinuit m(nll) ;

// MIGRAD likelihood minimization
m.migrad() ;

// Run HESSE error analysis
m.hesse() ;

// Set sx to 3, keep fixed in fit
sx.setVal(3) ;
sx.setConstant(kTRUE) ;

// MIGRAD likelihood minimization
m.migrad() ;

// Run MINOS error analysis
m.minos()

// Draw 1,2,3 'sigma' contours in sx,sy
m.contour(sx,sy) ;
```

# Minuit function MIGRAD

- Purpose: find minimum

Progress information,  
watch for errors here

\*\*\*\*\*

\*\* 13 \*\*MIGRAD 1000 1

\*\*\*\*\*

(some output omitted)

MIGRAD MINIMIZATION HAS CONVERGED.  
MIGRAD WILL VERIFY CONVERGENCE AND ERROR MATRIX  
COVARIANCE MATRIX CALCULATED SUCCESSFULLY

FCN=257.304 FROM MIGRAD STATUS=CONVERGED 31 CALLS 32 TOTAL  
EDM=2.36773e-06 STRATEGY= 1 ERROR MATRIX ACCURATE

EXT PARAMETER

NO.	NAME	VALUE	ERROR	STEP SIZE	FIRST DERIVATIVE
1	mean	8.84225e-02	3.23862e-01	3.58344e-04	-2.24755e-02
2	sigma	3.20763e+00	2.39540e-01	2.78628e-04	-5.34724e-02

ERR DEF= 0.5

EXTERNAL ERROR MATRIX. NDIM= 25 NPAR 2 ERR DEF=0.5

1.049e-01 3.338e-04

3.338e-04 5.739e-02

PARAMETER CORRELATION COEFFICIENTS

NO.	GLOBAL	1	2
1	0.00430	1.000	0.004
2	0.00430	0.004	1.000

Parameter values and approximate  
errors reported by MINUIT

Error definition (in this case 0.5 for  
a likelihood fit)

# Minuit function MIGRAD

- Purpose: find minimum

```
*****
** 13 **MIGR
*****
(some output of
MIGRAD MINIMIZ
MIGRAD WILL VERIF
COVARIANCE MATR
FCN=257.304 FROM MIGRAD STATUS=CONVERGED 31 CALLS 32 TOTAL
EDM=2.36773e-06 STRATEGY= 1 ERROR MATRIX ACCURATE
EXT PARAMETER STEP FIRST
NO. NAME VALUE ERROR SIZE DERIVATIVE
1 mean 8.84225e-02 3.23862e-01 3.58344e-04 -2.24755e-02
2 sigma 3.20763e+00 2.39540e-01 2.78628e-04 -5.34724e-02
ERR DEF= 0.5
EXTERNAL ERROR MATRIX. NDIM= 25 NPAR= 2 ERR DEF=0.5
1.049e-01 3.338e-04
3.338e-04 5.739e-02
PARAMETER CORRELATION COEFFICIENTS
NO. GLOBAL 1 2
1 0.00430 1.000 0.004
2 0.00430 0.004 1.000
```

Value of  $\chi^2$  or likelihood at minimum

(NB:  $\chi^2$  values are not divided by  $N_{d.o.f}$ )

Approximate Error matrix And covariance matrix



# Minuit function MIGRAD

- Purpose: find minimum

**Status:**  
Should be 'converged' but can be 'failed'

**Estimated Distance to Minimum**  
should be small  $O(10^{-6})$

**Error Matrix Quality**  
should be 'accurate', but can be  
'approximate' in case of trouble

\*\*\*\*\*

\*\* 13 \*\*MIGRAD 1000

\*\*\*\*\*

(some output omitted)

MIGRAD MINIMIZATION HAS CONVERGED

MIGRAD WILL VERIFY CONVERGENCE AND F... MATRIX.

COVARIANCE MATRIX CALCULATED SUCCESSFULLY

FCN=257.304 FROM MIGRAD STATUS=CONVERGED 31 CALLS 32 TOTAL

EDM=2.36773e-06 STRATEGY= 1 ERROR MATRIX ACCURATE

EXT	PARAMETER	VALUE	ERROR	STEP	FIRST
NO.	NAME			SIZE	DERIVATIVE
1	mean	8.84225e-02	3.23862e-01	3.58344e-04	-2.24755e-02
2	sigma	3.20763e+00	2.39540e-01	2.78628e-04	-5.34724e-02

ERR DEF= 0.5

EXTERNAL ERROR MATRIX. NDIM= 25 NPAR= 2 ERR DEF=0.5

1.049e-01 3.338e-04

3.338e-04 5.739e-02

PARAMETER CORRELATION COEFFICIENTS

NO.	GLOBAL	1	2
1	0.00430	1.000	0.004
2	0.00430	0.004	1.000

# Minuit function HESSE

- Purpose: calculate error matrix from  $\frac{d^2L}{dp^2}$

```
*****
**   18 **HESSE           1000
*****
COVARIANCE MATRIX CALCULATED SUCCESSFULLY
FCN=257.304 FROM HESSE      STATUS=OK
                                EDM=2.36534e-06  STRATA
                                TOTAL
                                CURATE
EXT PARAMETER
NO.   NAME      VALUE      ERROR      STEP SIZE  INTERNAL   INTERNAL
      NAME      VALUE      ERROR      STEP SIZE  VALUE
  1  mean      8.84225e-02  3.23861e-01  7.16689e-05  8.84237e-03
  2  sigma     3.20763e+00  2.39539e-01  5.57256e-05  3.26535e-01
                                ERR DEF= 0.5
EXTERNAL ERROR MATRIX.  NDIM= 25  NPAR= 2  ERR DEF=0.5
  1.049e-01  2.780e-04
  2.780e-04  5.739e-02
PARAMETER CORRELATION COEFFICIENTS
NO.  GLOBAL    1    2
  1  0.00358   1.000  0.004
  2  0.00358   0.004  1.000
```

Symmetric errors  
calculated from 2<sup>nd</sup>  
derivative of  $-\ln(L)$  or  $\chi^2$

ERROR  
3.23861e-01  
2.39539e-01

# Minuit function HESSE

- Purpose: calculate error matrix from  $\frac{d^2L}{dp^2}$

\*\*\*\*\*

\*\*

\*\*\*

COV SUCCESSFULLY

FCN TUS=OK 10 CALLS 42 TOTAL

EX 1e-06 STRATEGY= 1 ERROR MATRIX ACCURATE

NO INTERNAL INTERNAL

1 ERROR STEP SIZE VALUE

2 sid 3.20763e+00 2.39539e-01 5.57256e-05 3.26535e-01

ERR DEF= 0.5

NDIM= 25 NPAR= 2 ERR DEF=0.5

EXTERNAL ERROR MATRIX.

1.049e-01 2.780e-04

2.780e-04 5.739e-02

PARAMETER CORRELATION COEFFICIENTS

NO.	GLOBAL	1	2
1	0.00358	1.000	0.004
2	0.00358	0.004	1.000

Error matrix  
(Covariance Matrix)  
calculated from

$$V_{ij} = \left( \frac{d^2(-\ln L)}{dp_i dp_j} \right)^{-1}$$

# Minuit function HESSE

- Purpose: calculate error matrix from  $\frac{d^2L}{dp^2}$

```

*****
**  18 **HESSE          1000
*****
COVARIANCE MATRIX CALCULATED SUCCESSFULLY
FCN=257.304 FROM HESSE      STATUS=OK          10 CALLS          42 TOTAL
                        EDM=2.36534e-06      STRATEGY= 1          ERROR MATRIX ACCURATE

EXT PARAMETER                                INTERNAL          INTERNAL
NO.   NAME      VALUE                        ERROR            STEP SIZE        VALUE
  1  mean        8.84225e-02                            8.84237e-03
  2  sigma       3.20763e+00                            3.26535e-01

EXTERNAL ERROR MATRIX.      NDIM
  1.049e-01  2.780e-04
  2.780e-04  5.739e-02

PARAMETER CORRELATION COEFFICIENT
NO.   GLOBAL      1      2
  1  0.00358    1.000  0.004
  2  0.00358    0.004  1.000
    
```

Correlation matrix  $\rho_{ij}$   
calculated from

$$V_{ij} = \sigma_i \sigma_j \rho_{ij}$$

F=0.5

# Minuit function HESSE

- Purpose: calculate error matrix from  $\frac{d^2L}{dp^2}$

```
*****
**   18 **HESSE           1000
*****
COVARIANCE MATRIX CALCULATED SUCCESSFULLY
FCN=257.304 FROM HESSE      STATUS=OK           10 CALLS           42 TOTAL
                        EDM=2.36534e-06      STRATEGY= 1           ERROR MATRIX ACCURATE

EXT PARAMETER                INTERNAL          INTERNAL
NO.   NAME                   VALUE          ERROR          STEP SIZE      VALUE
  1   mean                   7.16689e-05   8.84237e-03
  2   sigma                   5.57256e-05   3.26535e-01

EXTERNAL ERROR                2      ERR DEF=0.5
1.049e-01  2.780e-04
2.780e-04  5.739e-05

PARAMETER CORRELATION COEFFICIENTS
NO.   GLOBAL          1          2
  1   0.00358         1.000     0.004
  2   0.00358         0.004     1.000
```

**Global correlation vector:  
correlation of each parameter  
with *all other* parameters**

# Minuit function MINOS

- Error analysis through  $\Delta nll$  contour finding

```
*****
**   23 **MINOS           1000
*****
FCN=257.304 FROM MINOS      STATUS=SUCCESSFUL      52 CALLS           94 TOTAL
                        EDM=2.36534e-06      STRATEGY= 1           ERROR MATRIX ACCURATE

EXT PARAMETER
NO.   NAME      VALUE
  1   mean      8.84225e-02
  2   sigma     3.20763e+00
                        PARABOLIC
                        ERROR
                        MINOS ERRORS
                        NEGATIVE      POSITIVE
  1   mean      3.23861e-01      -3.24688e-01      3.25391e-01
  2   sigma     2.39539e-01      -2.23321e-01      2.58893e-01
                        ERP DEF= 0.5
```

**Symmetric error**  
(repeated result  
from HESSE)

**MINOS error**  
Can be asymmetric  
(in this example the 'sigma' error  
is slightly asymmetric)

## What happens if there are problems in the NLL calculation

---

- Sometimes the likelihood cannot be evaluated due to an error condition.
  - PDF Probability is zero, or less than zero at coordinate where there is a data point 'infinitely improbable'
  - Normalization integral of PDF evaluates to zero
- Most problematic during MINUIT operations. How to handle error condition
  - All error conditions are gathered and reported in a consolidated way by RooMinuit
  - Since MINUIT has no interface to deal with such situations, RooMinuit passes instead a large value to MINUIT to force it to retreat from the region of parameter space in which the problem occurred

```
[#0] WARNING:Minimization -- RooFitGlue: Minimized function has error status.  
Returning maximum FCN so far (99876) to force MIGRAD to back out of this region.  
Error log follows. Parameter values: m=-7.397  
RooGaussian::gx[ x=x mean=m sigma=sx ] has 3 errors
```

## What happens if there are problems in the NLL calculation

- Can request more verbose error logging to debug problem
  - Add `PrintEvalError(N)` with  $N > 1$

```
[#0] WARNING:Minization -- RooFitGlue: Minimized function has error status.  
Returning maximum FCN so far (-1e+30) to force MIGRAD to back out of this region.  
Error log follows  
Parameter values: m=-7.397  
RooGaussian::gx[ x=x mean=m sigma=sx ]  
  getLogVal() top-level p.d.f evaluates to zero or negative number  
    @ x=x=9.09989, mean=m=-7.39713, sigma=sx=0.1  
  getLogVal() top-level p.d.f evaluates to zero or negative number  
    @ x=x=6.04652, mean=m=-7.39713, sigma=sx=0.1  
  getLogVal() top-level p.d.f evaluates to zero or negative number  
    @ x=x=2.48563, mean=m=-7.39713, sigma=sx=0.1
```



# Practical estimation – Fit converge problems

- Sometimes fits don't converge because, e.g.
  - MIGRAD unable to find minimum
  - HESSE finds negative second derivatives (which would imply negative errors)
- Reason is usually numerical precision and stability problems, but
  - The **underlying cause** of fit stability problems is usually by **highly correlated parameters** in fit
- HESSE correlation matrix in primary investigative tool

PARAMETER NO.	CORRELATION GLOBAL	COEFFICIENTS	
		1	2
1	0.99835	1.000	0.998
2	0.99835	0.998	1.000

*Signs of trouble...*

- In limit of 100% correlation, the usual **point solution** becomes a **line solution** (or surface solution) in parameter space. Minimization problem is no longer well defined

# Mitigating fit stability problems

- Strategy I – More orthogonal choice of parameters
  - Example: fitting sum of 2 Gaussians of similar width

$$F(x; f, m, s_1, s_2) = fG_1(x; s_1, m) + (1 - f)G_2(x; s_2, m)$$

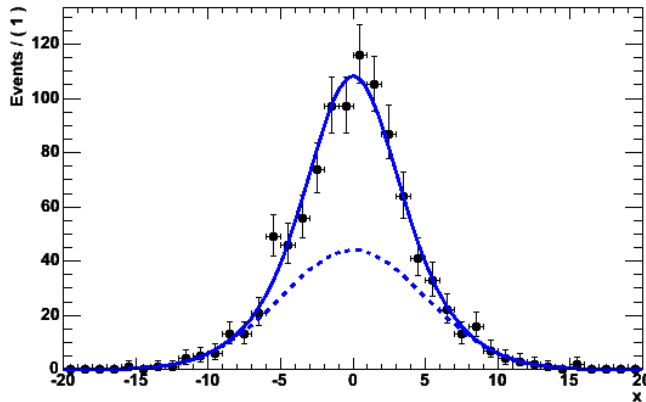

HESSE correlation matrix

**Widths  $s_1, s_2$   
strongly correlated  
fraction  $f$**

PARAMETER	CORRELATION COEFFICIENTS				
NO.	GLOBAL	[ f ]	[ m ]	[ s1 ]	[ s2 ]
[ f ]	0.96973	1.000	-0.135	0.918	0.915
[ m ]	0.14407	-0.135	1.000	-0.144	-0.114
[ s1 ]	0.92762	0.918	-0.144	1.000	0.786
[ s2 ]	0.92486	0.915	-0.114	0.786	1.000

# Mitigating fit stability problems

- Different parameterization:

$$fG_1(x; s_1, m_1) + (1-f)G_2(x; \underline{s_1 \cdot s_2}, m_2)$$

PARAMETER	CORRELATION COEFFICIENTS				
NO.	GLOBAL	[f]	[m]	[s1]	[s2]
[ f ]	0.96951	1.000	-0.134	0.917	-0.681
[ m ]	0.14312	-0.134	1.000	-0.143	0.127
[s1]	0.98879	0.917	-0.143	1.000	-0.895
[s2]	0.96156	0.681	0.127	-0.895	1.000

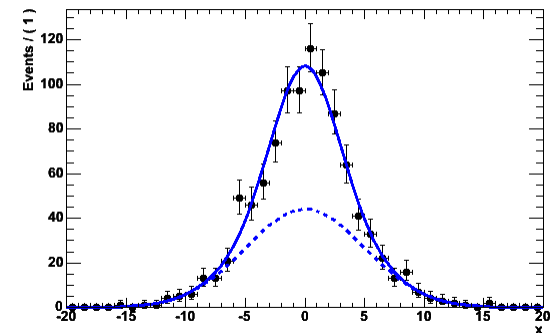

- Correlation of width s2 and fraction f reduced from 0.92 to 0.68
  - Choice of parameterization matters!
- Strategy II – Fix all but one of the correlated parameters
    - If floating parameters are highly correlated, some of them may be redundant and not contribute to additional degrees of freedom in your model

# Mitigating fit stability problems -- Polynomials

- **Warning:** Regular parameterization of polynomials  $a_0 + a_1x + a_2x^2 + a_3x^3$  nearly always results in strong correlations between the coefficients  $a_i$ .
  - *Fit stability problems, inability to find right solution common at higher orders*
- **Solution:** Use existing parameterizations of polynomials that have (mostly) uncorrelated variables
  - **Example: Chebychev polynomials**

$$T_0(x) = 1$$

$$T_1(x) = x$$

$$T_2(x) = 2x^2 - 1$$

$$T_3(x) = 4x^3 - 3x$$

$$T_4(x) = 8x^4 - 8x^2 + 1$$

$$T_5(x) = 16x^5 - 20x^3 + 5x$$

$$T_6(x) = 32x^6 - 48x^4 + 18x^2 - 1.$$

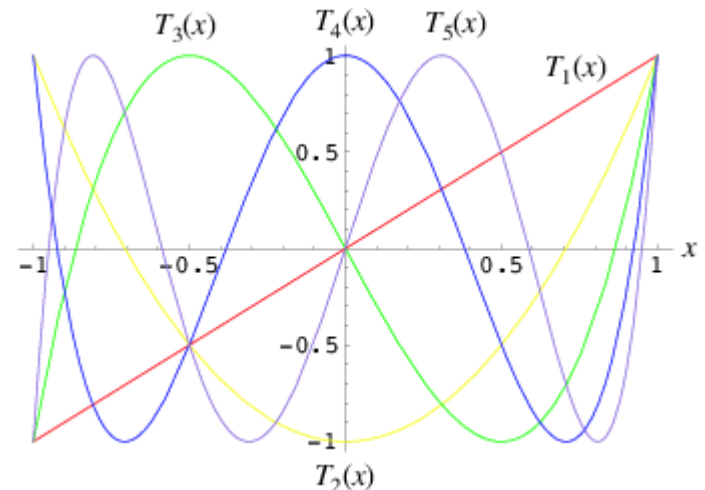

## Minuit CONTOUR tool also useful to examine 'bad' correlations

- Example of 1,2 sigma contour of two uncorrelated variables
  - Elliptical shape. In this example parameters are uncorrelation

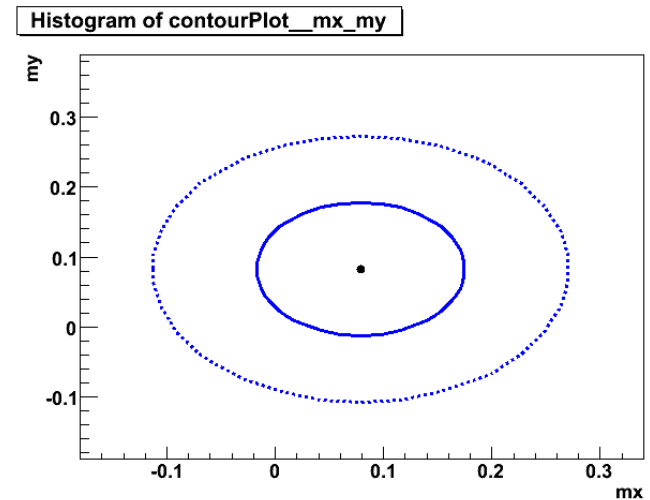

- Example of 1,2 sigma contour of two variables with problematic correlation
  - Pdf =  $f \cdot G1(x,0,3) + (1-f) \cdot G2(x,0,s)$  with  $s=4$  in data

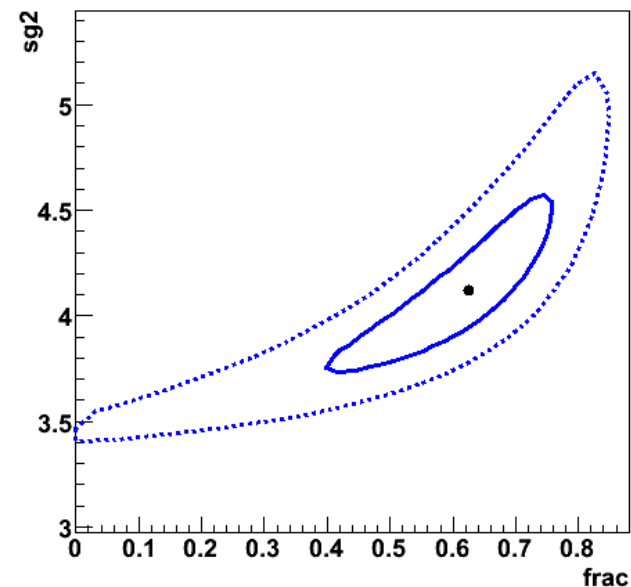
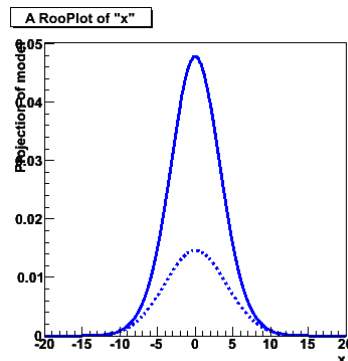

# Practical estimation – Bounding fit parameters

- Sometimes is it desirable to bound the allowed range of parameters in a fit
  - Example: a fraction parameter is only defined in the range  $[0,1]$
  - MINUIT option 'B' maps finite range parameter to an internal infinite range using an arcsin(x) transformation:

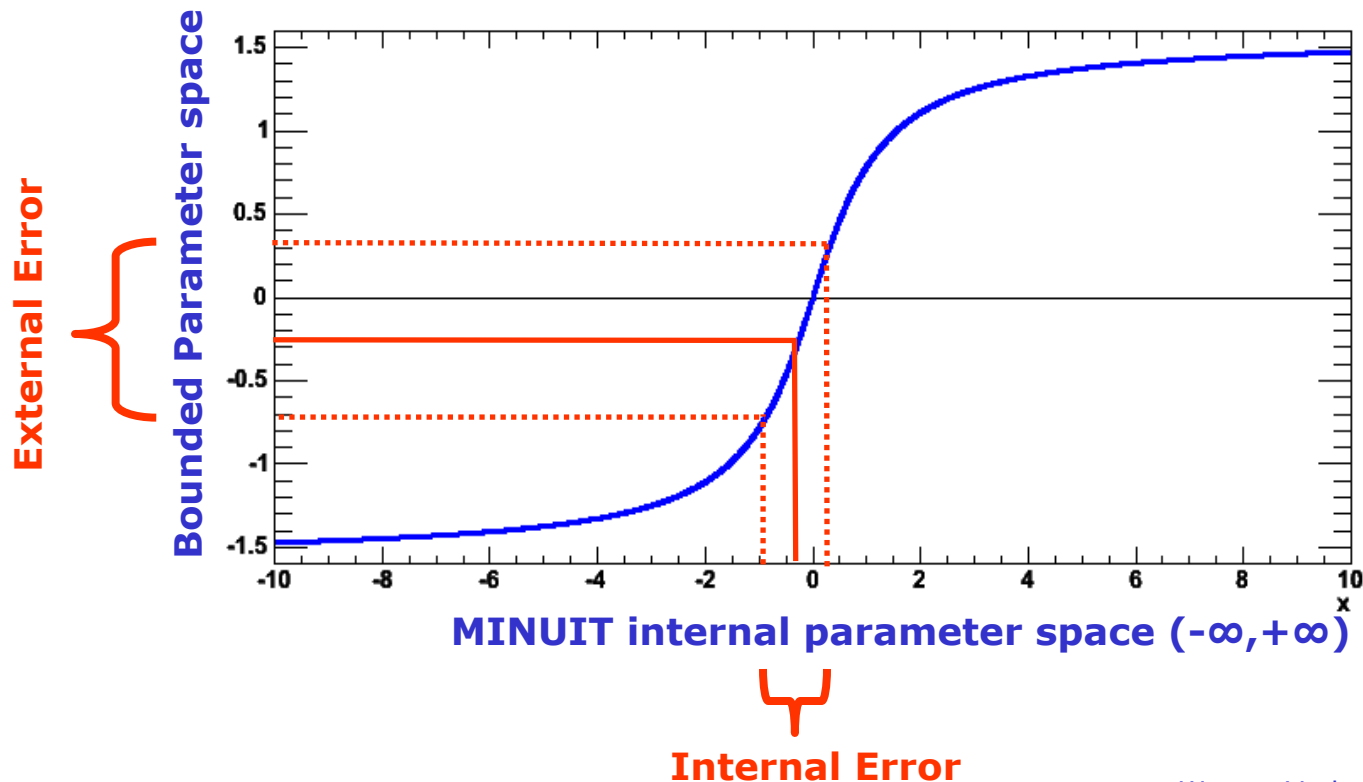

# Practical estimation – Bounding fit parameters

- If fitted parameter values is close to boundary, **errors** will become **asymmetric** (and possible incorrect)

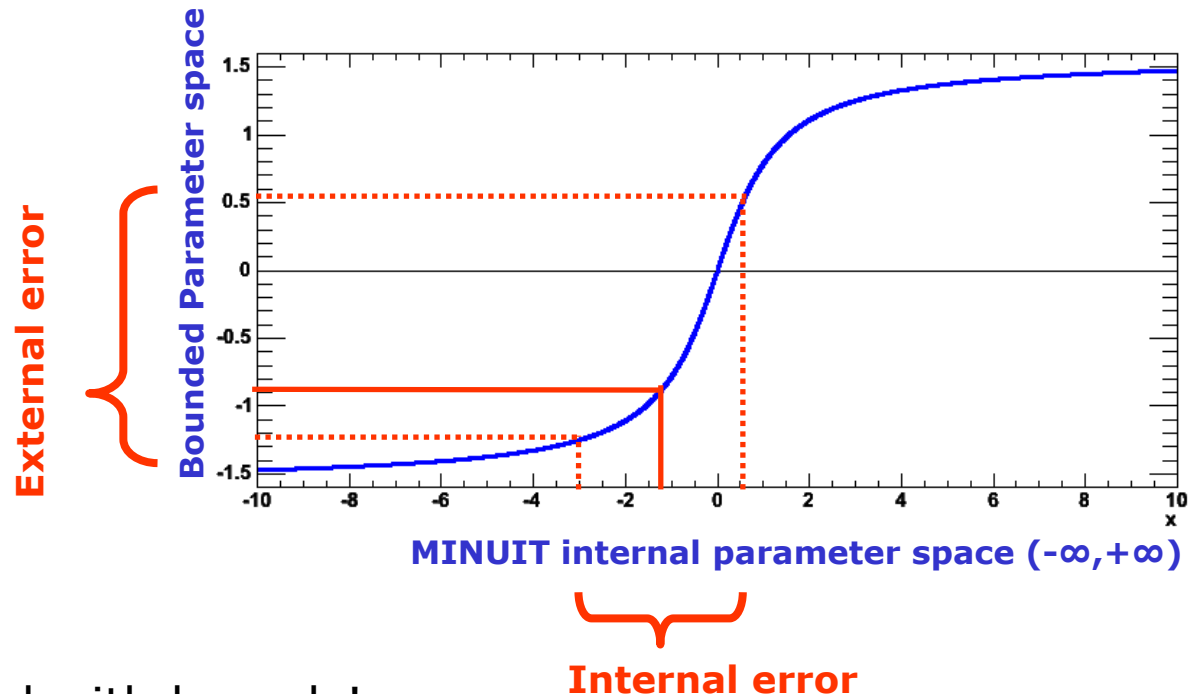

- So be careful with bounds!
  - If boundaries are imposed to avoid region of instability, look into other parameterizations that naturally avoid that region
  - If boundaries are imposed to avoid 'unphysical', but statistically valid results, consider not imposing the limit and dealing with the 'unphysical' interpretation in a later stage

# Browsing fit results with `RoofitResult`

- As fits grow in complexity (e.g. 45 floating parameters), number of output variables increases
  - Need better way to navigate output than MINUIT screen dump
- `RoofitResult` holds complete snapshot of fit results
  - Constant parameters
  - Initial and final values of floating parameters
  - Global correlations & full correlation matrix
  - Returned from `RoofitAbsPdf::fitTo()` when "r" option is supplied
- Compact & verbose printing mode

Compact Mode

```
fitres->Print() ;
```

```
RoofitResult: min. NLL value: 1.6e+04, est. distance to min: 1.2e-05
```

Floating Parameter	FinalValue +/-	Error
-----	-----	-----
argpar	-4.6855e-01 +/-	7.11e-02
g2frac	3.0652e-01 +/-	5.10e-03
mean1	7.0022e+00 +/-	7.11e-03
mean2	1.9971e+00 +/-	6.27e-03
sigma	2.9803e-01 +/-	4.00e-03

Constant parameters omitted in compact mode

Alphabetical parameter listing



# Browsing fit results with RooFitResult

Verbose printing mode

```
fitres->Print("v") ;
```

```
RooFitResult: min. NLL value: 1.6e+04, est. distance to min: 1.2e-05
```

```
Constant Parameter      Value
```

```
-----  
      cutoff      9.0000e+00  
      g1frac      3.0000e-01
```

} Constant parameters  
listed separately

```
Floating Parameter      InitialValue      FinalValue +/-      Error      GblCorr.  
-----  
      argpar      -5.0000e-01      -4.6855e-01 +/-      7.11e-02      0.191895  
      g2frac      3.0000e-01      3.0652e-01 +/-      5.10e-03      0.293455  
      mean1      7.0000e+00      7.0022e+00 +/-      7.11e-03      0.113253  
      mean2      2.0000e+00      1.9971e+00 +/-      6.27e-03      0.100026  
      sigma      3.0000e-01      2.9803e-01 +/-      4.00e-03      0.276640
```

} Initial,final value and global corr. listed side-by-side

Correlation matrix accessed separately

# Browsing fit results with `RooFitResult`

---

- Easy navigation of correlation matrix
  - Select single element or complete row by parameter name

```
r->correlation("argpar", "sigma")
(const Double_t) (-9.25606412005910845e-02)

r->correlation("mean1")->Print("v")
RooArgList::C[mean1,*]: (Owning contents)
  1) RooRealVar::C[mean1,argpar] : 0.11064 C
  2) RooRealVar::C[mean1,g2frac] : -0.0262487 C
  3) RooRealVar::C[mean1,mean1] : 1.0000 C
  4) RooRealVar::C[mean1,mean2] : -0.00632847 C
  5) RooRealVar::C[mean1,sigma] : -0.0339814 C
```

- `RooFitResult` persistable with ROOT I/O
  - Save your batch fit results in a ROOT file and navigate your results just as easy afterwards

# Visualize errors and correlation matrix elements

```
RooFitResult* r = pdf->fitTo(data,"mhvr") ;  
RooPlot* f = new RooPlot(tau,sigma1,1.35,1.6,0.85,1.20) ;  
r->plotOn(f,tau,sigma1,"ME12VHB") ;  
f->Draw() ;
```

Works on any `RooFitResult`,  
Also after persistence

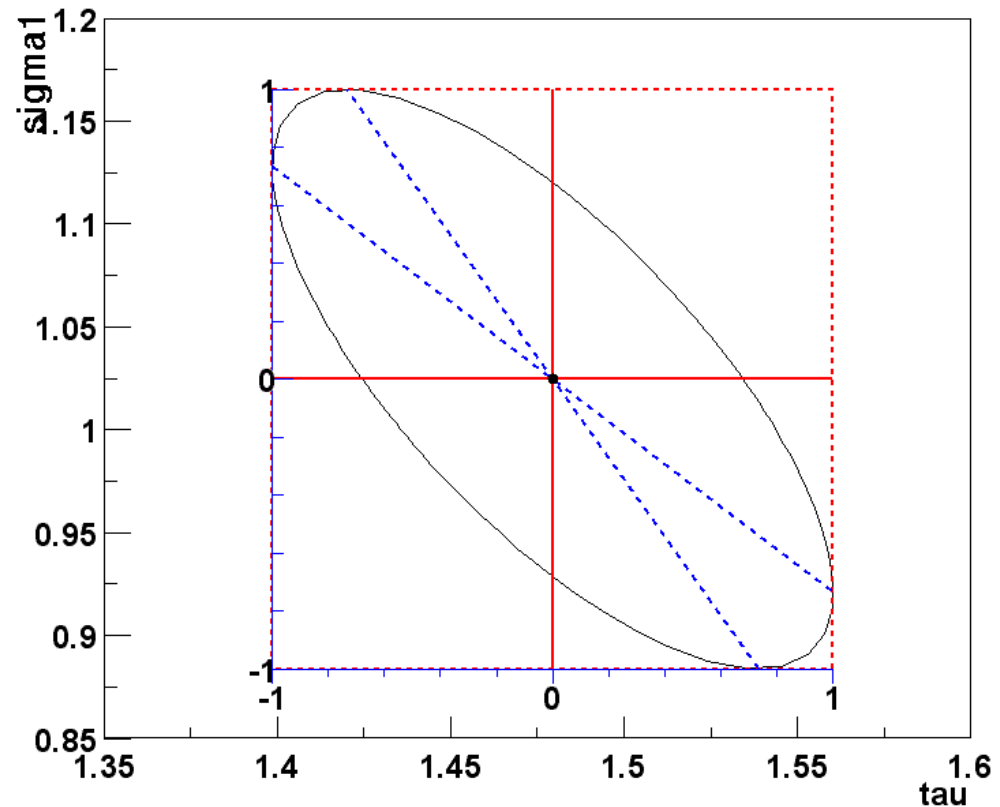

MINUIT contour scan  
is also possible with  
a separate interface

## Working with *profile* likelihoods

---

- Given a likelihood, the profile likelihood is defined as
  - Where the hatted quantities represent the value of that parameter at which the  $-\log(L)$  is minimal

$$PL(p) = \frac{L(p, \hat{q})}{L(\hat{p}, \hat{q})}$$

- Represented in RooFit with class `RooProfileLL`

```
// First make regular likelihood object (with parameters frac and sg2)
RooNLLVar nll("nll","nll",model,*data) ;

// Now make profile likelihood in frac
RooProfileLL pll_frac("pll_frac","pll",nll,frac) ;
```

- A profile likelihood is a regular function object in RooFit, you can plot it with `plotOn()` etc.
- However it is expensive, as each function evaluation requires a MIGRAD minimization step!

# Plotting a profile likelihood

- Example with strong correlations:
  - sum of two Gaussians with similar widths and floating fraction

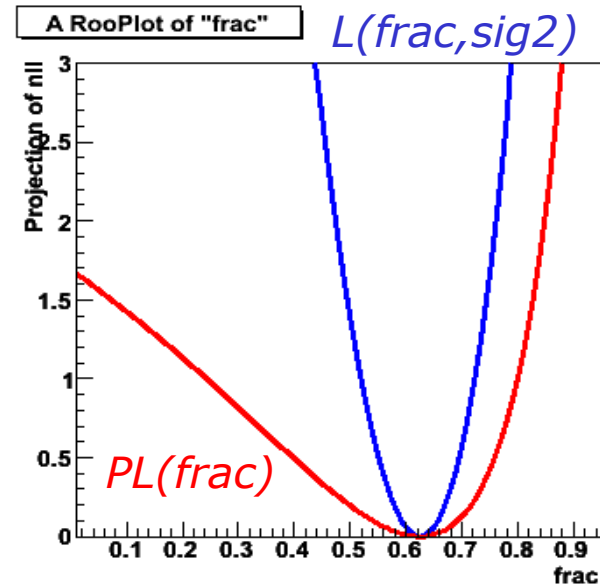
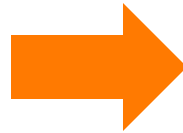
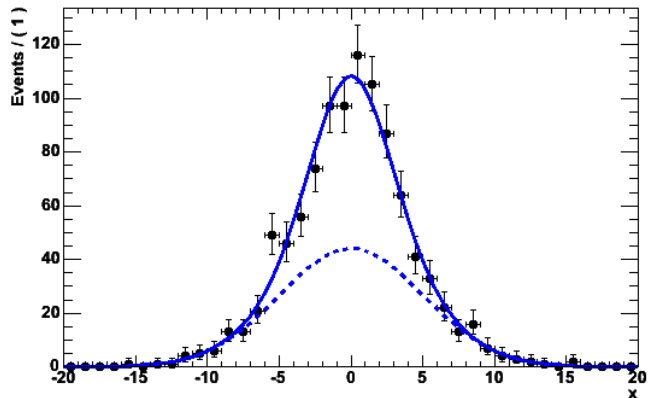

- Profile likelihood much broader than likelihood because changing the width the 2<sup>nd</sup> gaussian can largely compensate for off-value of fraction

# Relation between MINOS errors and profile likelihood

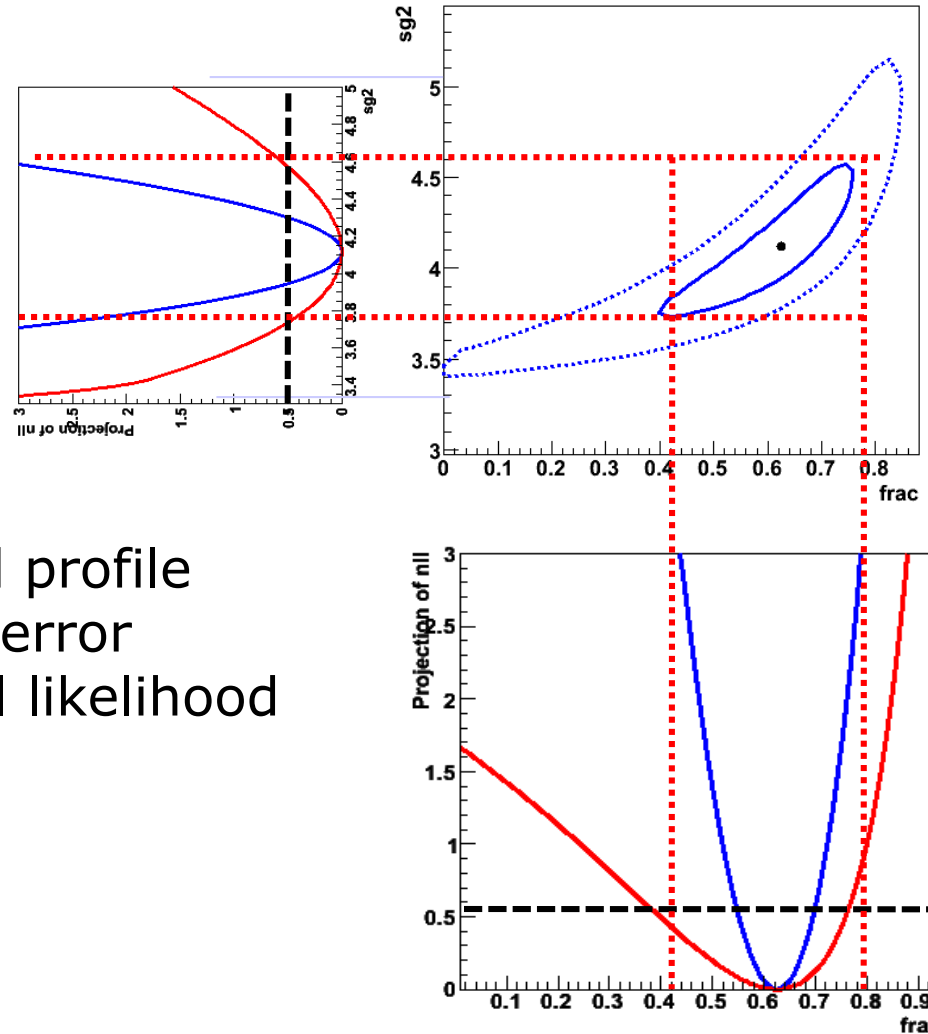

- MINOS error box and profile likelihood give same error for multi-dimensional likelihood

## Other uses of likelihood

---

- A likelihood may be considered the ultimate publication of a measurement
- Interesting to be able to digitally publish **actual likelihood** rather than
  - Parabolic version (i.e. you publish your measurement and an error)
  - Some parameterized form. Cumbersome in  $>1$  dimension. No standard protocol for exchanging this type of information
- You can do this now in RooFit
  - You can persist your data (previously possible) and your actual p.d.f or likelihood into a ROOT file that anyone can read and use
- Many potential applications
  - Combining of Higgs channels, Heavy flavor averaging (CKMfitter) etc...

## Using the Workspace concept

---

- Up to now, to share with colleagues need to distribute *both* a data file and a ROOT macro that builds the RooFit p.d.f
- Now add the **Workspace** – Persistent container for both data and functions

```
RooAbsPdf& g ; // from preceding example  
RooAbsData& d ; // from preceding example
```

*Create the  
workspace  
container object*

```
{ RooWorkspace w("w", "my workspace") ;  
  w.import(g) ;  
  w.import(d) ;
```

*Use standard  
ROOT I/O  
to store wspace*

```
{ TFile f("myresult.root", "RECREATE") ;  
  w.Write() ;  
  f.Close() ;
```

- Both data and p.d.f. are now stored in file!



# A look at the workspace

---

- What is in the workspace?

```
w.Print() ;
```

```
Rooworkspace(w) my workspace contents
```

```
variables
```

```
-----
```

```
(x,m,s) → RoorealVar* x = w.get("x") ;
```

```
p.d.f.s
```

```
-----
```

```
Roogaussian::g[ x=x mean=m sigma=s ] = 0 → Roopdf* g = w.pdf("g") ;
```

```
datasets
```

```
-----
```

```
RoodataSet::d(x) → Roodata* d = w.data("d") ;
```

# Using persisted p.d.f.s.

- Using both model & p.d.f from file

```
TFile f("myresults.root") ;  
Rooworkspace* w = f.Get("w") ;
```

Make plot  
of data  
and p.d.f

```
RooPlot* xframe = w->var("x")->frame() ;  
w->data("d")->plotOn(xframe) ;  
w->pdf("g")->plotOn(xframe) ;
```

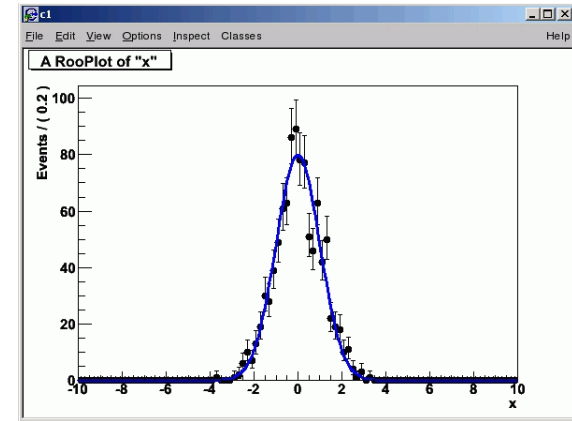

Construct  
likelihood  
& profile LH

```
RooNLLVar nll("nll", "nll", *w->pdf("g"), *w->data("d")) ;  
RooProfileLL p11("p11", "p11", nll, *w->var("m")) ;
```

Draw  
profile LH

```
RooPlot* mframe = w->var("m")->frame(-1,1) ;  
p11.plotOn(mframe) ;  
mframe->Draw()
```

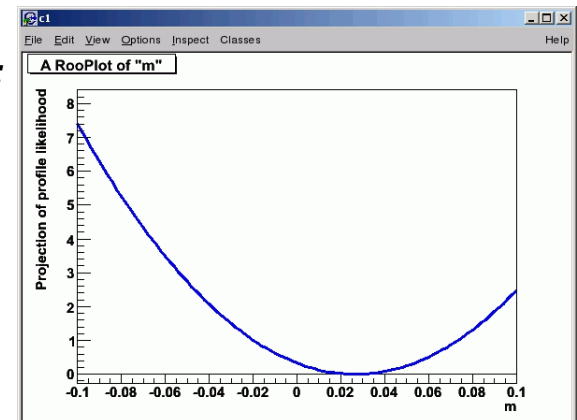

- Note that above code is independent of actual p.d.f in file → e.g. full Higgs combination would work with identical code

# A combination example

- Code constructing 'ATLAS' p.d.f with signal and background and data
  - PDF is Gaussian + Chebychev

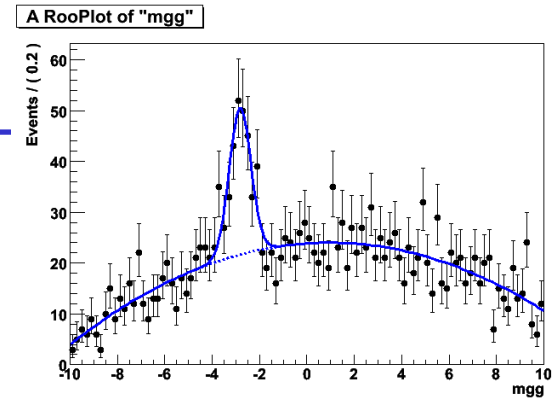

Create  
signal  
p.d.f

```
RooRealVar mgg("mgg", "mgg", -10, 10) ;  
RooRealVar mHiggs("mHiggs", "mHiggs", -3, -10, 10) ;  
RooRealVar sHiggs("sHiggs", "sHiggs", 0.5, 0.01, 10) ;  
RooGaussian sig("sig", "sig", mgg, mHiggs, sHiggs) ;
```

Create  
bkg  
p.d.f

```
RooRealVar a0("a0", "a0", 0.2, -1, 1) ;  
RooRealVar a1("a1", "a1", -0.5, -1, 1) ;  
RooRealVar a2("a2", "a2", 0.02, -1, 1) ;  
RooChebychev bkg("bkg", "bkg", mgg, RooArgList(a0, a1, a2)) ;
```

Create  
combined  
p.d.f

```
RooRealVar nHiggs("nHiggs", "nHiggs", 500, -100., 1000.) ;  
RooRealVar nBkg("nBkg", "nBkg", 5000, -100., 10000.) ;  
RooAddPdf model("model", "model", RooArgList(sig, bkg),  
RooArgList(nHiggs, nBkg)) ;
```

Generate  
toy data

```
RooDataSet* data = model.generate(mgg, NumEvents(2000), Name("data")) ;
```

# A combination example

---

- Code writing 'ATLAS' p.d.f and data into Workspace
  - Variation of toy Gauss example:  
***also create & persist likelihood function here***

*Fit model to data  
(skip MINOS)*

```
model.fitTo(*data, Extended(), Minos(kFALSE)) ;
```

***Create likelihood  
function***

```
RoوNLLVar n11("n11", "n11", model, *data, Extended()) ;
```

*Create the  
workspace  
container object*

```
RoوWorkspace atlas("atlas", "atlas") ;
```

```
atlas.import(model) ;
```

```
atlas.import(*data) ;
```

```
atlas.import(n11) ;
```

*Use standard  
ROOT I/O  
to store wspace*

```
TFile f("atlas.root", "RECREATE") ;
```

```
atlas.Write() ;
```

```
f.Close() ;
```

# A combination example

---

- Contents of the ATLAS workspace

```
root [4] atlas->Print()
```

```
Rooworkspace(atlas) atlas contents
```

```
variables
```

```
-----
```

```
(mgg, mHiggs, sHiggs, nHiggs, a0, a1, a2, nBkg)
```

```
p.d.f.s
```

```
-----
```

```
RooAddPdf::model[ pdfs=(sig,bkg) coefficients=(nHiggs,nBkg) ] = 0
```

```
RooGaussian::sig[ x=mgg mean=mHiggs sigma=sHiggs ] = 0
```

```
RooChebychev::bkg[ x=mgg coefList=(a0,a1,a2) ] = 0
```

```
functions
```

```
-----
```

```
RooNLLVar::nll[ params=(mHiggs,sHiggs,a0,a1,a2,nHiggs,nBkg) ] = 0
```

```
datasets
```

```
-----
```

```
RooDataSet::data(mgg)
```

*All component  
pdfs are visible  
as well*

# A combination example

- Similar code for 'CMS' – p.d.f. is Voigtian + Exponential

```
RooRealVar mgg("mgg", "mgg", -10, 10) ;  
RooRealVar mHiggs("mHiggs", "mHiggs", -3, -10, 10) ;  
RooRealVar wHiggs("wHiggs", "wHiggs", 0.8, 0.1, 10) ;  
RooRealVar sHiggs("sHiggs", "sHiggs", 0.3) ;  
RooVoigtian sig("sig", "sig", mgg, mHiggs, wHiggs, sHiggs) ;  
RooRealVar slope("slope", "slope", -0.2, -100, 1) ;  
RooExponential bkg("bkg", "bkg", mgg, slope) ;  
RooRealVar nHiggs("nHiggs", "nHiggs", 500, -500., 10000.) ;  
RooRealVar nBkg("nBkg", "nBkg", 5000, 0., 10000.) ;  
RooAddPdf model("model", "model", RooArgList(sig, bkg), RooArgList(nHiggs, nBkg)) ;
```

```
RooDataSet* data = model.generate(mgg, NumEvents(2000), Name("data")) ;  
model.fitTo(*data, Extended(), Minos(kFALSE)) ;  
RooNLLVar nll("nll", "nll", model, *data, Extended()) ;
```

```
RooWorkspace cms("cms", "cms") ;  
cms.import(model) ;  
cms.import(*data) ;  
cms.import(nll) ;  
cms.Print() ;
```

```
TFile f("cms.root", "RECREATE") ;  
cms.Write() ;  
f.Close() ;
```

A RooPlot of "mgg"

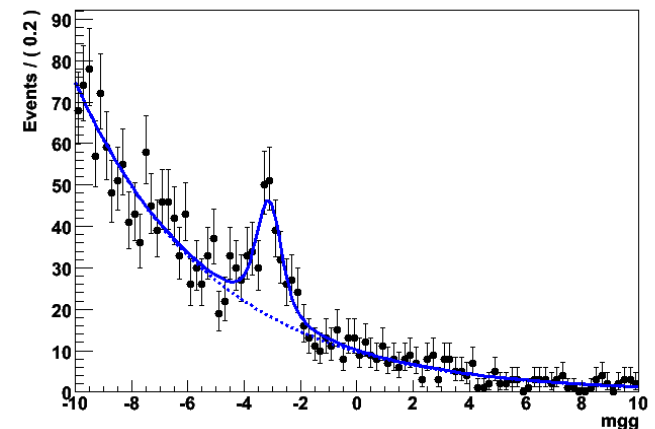

# A combination example

---

- Combining 'ATLAS' and 'CMS' result from persisted workspaces

*Read ATLAS workspace* { `TFile* f = new TFile("atlas.root") ;`  
`RoWorkspace *atlas = f->Get("atlas") ;`

*Read CMS workspace* { `TFile* f = new TFile("cms.root") ;`  
`RoWorkspace *cms = f->Get("cms") ;`

*Construct combined LH* { `RoAddition n11Combi("n11Combi","n11 CMS&ATLAS",`  
`RoArgSet(*cms->function("n11"),*atlas->function("n11")) ;`

*Construct profile LH in mHiggs* { `RoProfileLL p11Combi("p11Combi","p11",n11Combi,*atlas->var("mHiggs")) ;`

*Plot Atlas, CMS, combined profile LH* { `RoPlot* mframe = atlas->var("mHiggs")->frame(-3.5,-2.5) ;`  
`atlas->function("n11")->plotOn(mframe) ;`  
`cms->function("n11")->plotOn(mframe,LineStyle(kDashed)) ;`  
`p11Combi.plotOn(mframe,LineColor(kRed)) ;`  
`mframe->Draw() ; // result on next slide`

# A combination example

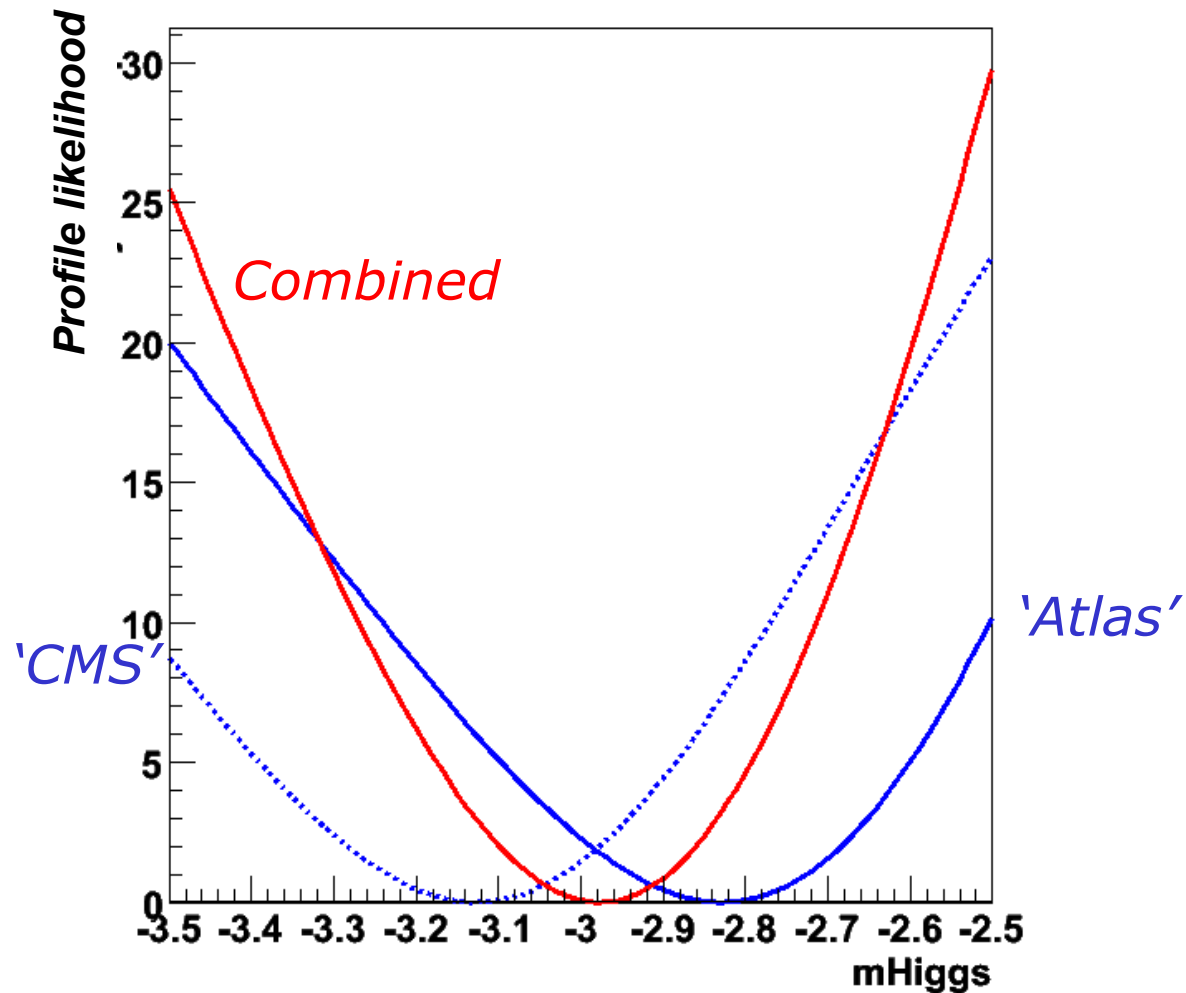



# 7 Fit validation, Toy MC studies

- *Goodness-of-fit,  $\chi^2$*
- *Toy Monte Carlo studies for fit validation*

# How do you know if your fit was 'good'

- Goodness-of-fit broad issue in statistics in general, will just focus on a few specific tools implemented in RooFit here
- For one-dimensional fits, a  $\chi^2$  is usually the right thing to do
  - Some tools implemented in RooPlot to be able to calculate  $\chi^2/\text{ndf}$  of curve w.r.t data

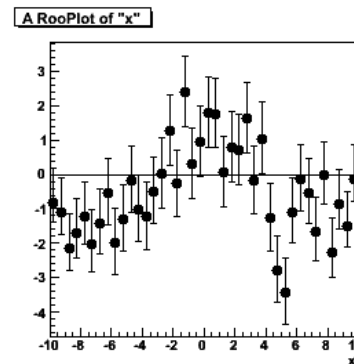
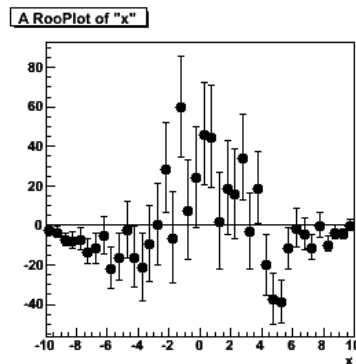
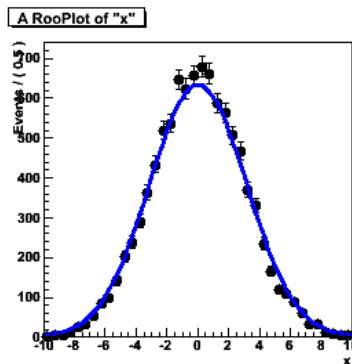

- Also tools exists to plot residual and pull distributions from curve and histogram in a RooPlot

```
frame->makePullHist() ;  
frame->makeResidHist() ;
```

## GOF in >1D, other aspects of fit validity

---

- No special tools for >1 dimensional goodness-of-fit
  - A  $\chi^2$  usually doesn't work because empty bins proliferate with dimensions
  - But if you have ideas you'd like to try, there exists generic base classes for implementation that provide the same level of computational optimization and parallelization as is done for likelihoods (`RooAbsOptTestStatistic`)
- But you can study many other aspect of your fit validity
  - Is your fit unbiased?
  - Does it (often) have convergence problems?
- You can answer these with a toy Monte Carlo study
  - I.e. generate 10000 samples from your p.d.f., fit them all and collect and analyze the statistics of these 10000 fits.
  - The `RooMCStudy` class helps out with the logistics

# Advanced features – Task automation

- Support for routine task automation, e.g. goodness-of-fit study

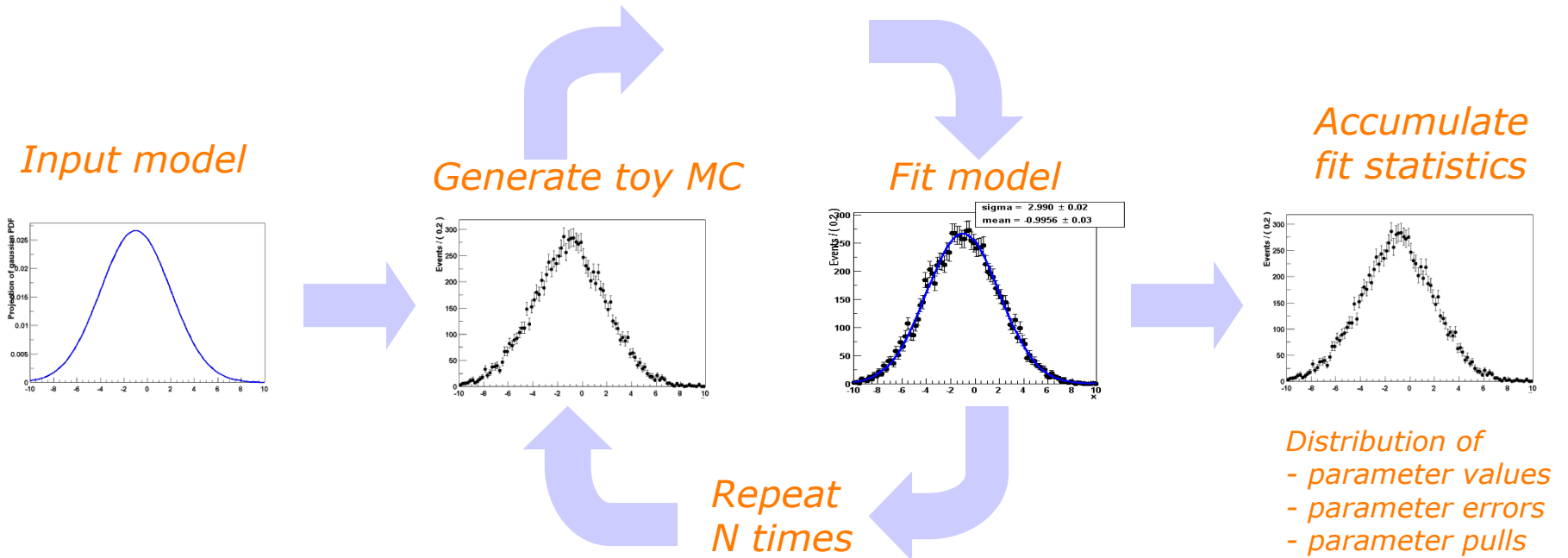

```
// Instantiate MC study manager
RoomCStudy mgr(inputModel) ;

// Generate and fit 100 samples of 1000 events
mgr.generateAndFit(100,1000) ;

// Plot distribution of sigma parameter
mgr.plotParam(sigma) ->Draw()
```

## How to *efficiently* generate multiple sets of ToyMC?

---

- Use **RoomCStudy** class to manage generation and fitting
- Generating features
  - *Generator overhead only incurred once*  
→ Efficient for large number of small samples
  - Optional Poisson distribution for #events of generated experiments
  - Optional automatic creation of ASCII data files
- Fitting
  - Fit with generator PDF or different PDF
  - Fit *results* (floating parameters & NLL)  
automatically *collected in summary dataset*
- Plotting
  - Automated plotting for distribution of parameters, parameter errors, pulls and NLL
- Add-in modules for optional modifications of procedure
  - Concrete tools for variation of generation parameters, calculation of likelihood ratios for each experiment
  - Easy to write your own. You can intervene at any stage and offer proprietary data to be aggregated with fit results

# A RooMCStudy example

- Generating and fitting a simple PDF

```
// Setup PDF
RooRealVar x("x","x",-5,15) ;
RooRealVar mean("mean","mean of gaussian",-1) ;
RooRealVar sigma("sigma","width of gaussian",4) ;
RooGaussian gauss("gauss","gaussian PDF",x,mean,sigma) ;
```

```
// Create manager
RooMCStudy mgr(gauss,gauss,x,"","mhv") ;
```

Generator PDF

Generator Options

Fitting PDF

Fitting Options

Observables

```
// Generate and fit 1000 experiments of 100 events each
mgr.generateAndFit(1000,100) ;
```

```
RooMCStudy::run: Generating and fitting sample 999
```

```
RooMCStudy::run: Generating and fitting sample 998
```

```
RooMCStudy::run: Generating and fitting sample 997
```

```
...
```

# A RooMCStudy example

- Plot the distribution of the value, error and pull of *mean*

```
// Plot the distrution of the value
RooPlot* mframe = mean.frame(-2,0) ;
mgr.plotParamOn(mframe) ;
mframe->Draw() ;

// Plot the distrution of the error
RooPlot* meframe = mgr.plotError(mean,0.,0.1) ;
meframe->Draw() ;

// Plot the distrution of the pull
RooPlot* mpframe = mgr.plotPull(mean,-3,3,40,kTRUE) ;
mpframe->Draw() ;
```

Add Gaussian fit

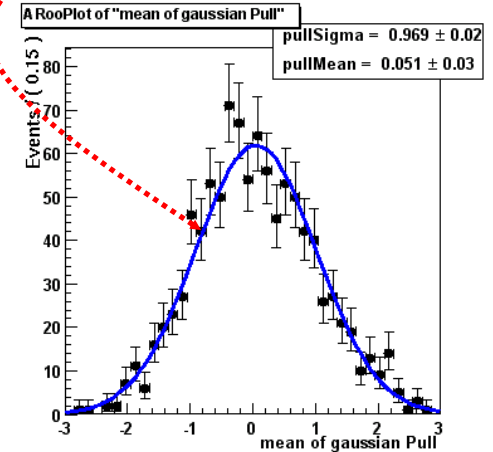
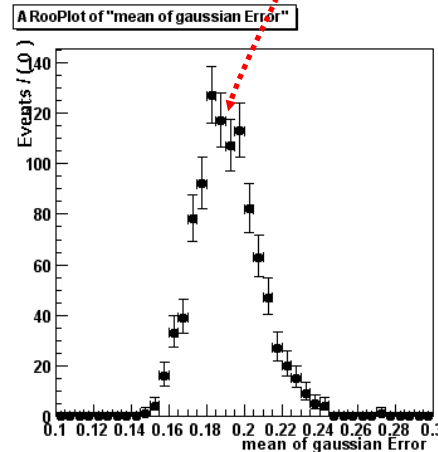
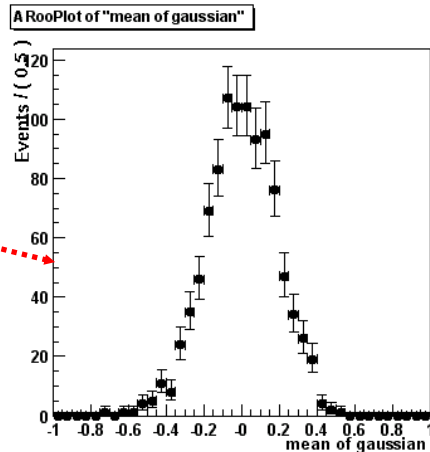

# A RooMCStudy example

- Plot the distribution of  $-\log(L)$

```
// Plot the distribution of the NLL  
mgr.plotNLL(mframe) ;  
mframe->Draw() ;
```

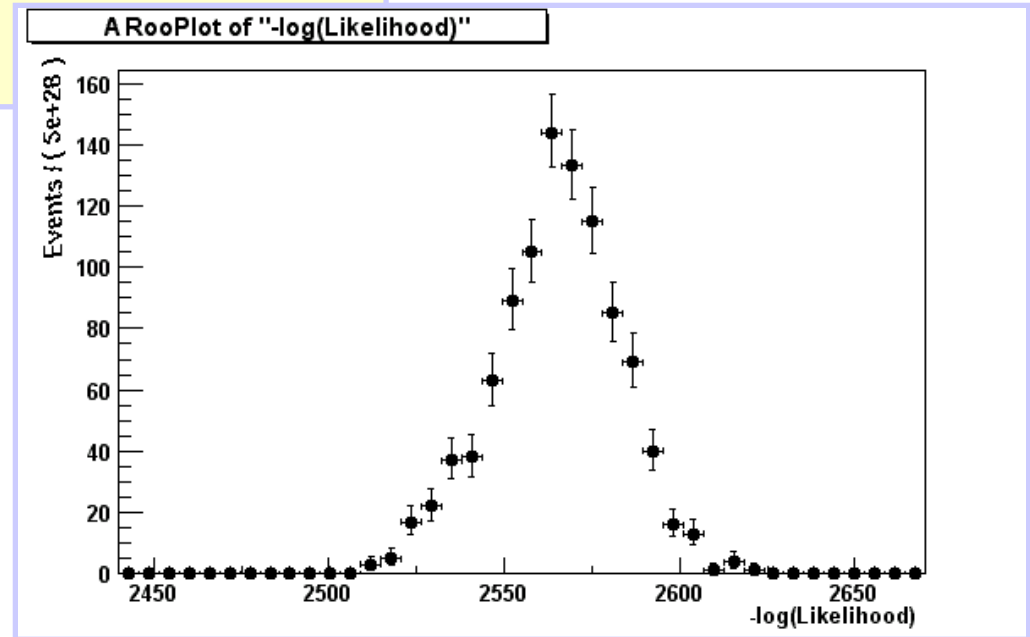

- NB: likelihood distributions cannot be used to deduce goodness-of-fit information!



# A RooMCStudy example

- For other uses, use summarized fit results in `RooDataSet` form

```
mgr.fitParDataSet().get(10) ->Print("v") ;  
RooArgSet:::
```

```
1) RooRealVar::mean      :  0.14814 +/- 0.191 L(-10 - 10)  
2) RooRealVar::sigma     :  4.0619 +/- 0.143 L(0 - 20)  
3) RooRealVar::NLL       :  2585.1 C  
4) RooRealVar::meanerr   :  0.19064 C  
5) RooRealVar::meanpull  :  0.77704 C  
6) RooRealVar::sigmaerr  :  0.14338 C  
7) RooRealVar::sigmapull :  0.43199 C
```

```
TH2* h = mean.createHistogram("mean vs sigma",sigma) ;  
mgr.fitParDataSet().fillHistogram(h,RooArgList(mean,sigma)) ;  
h->Draw("BOX") ;
```

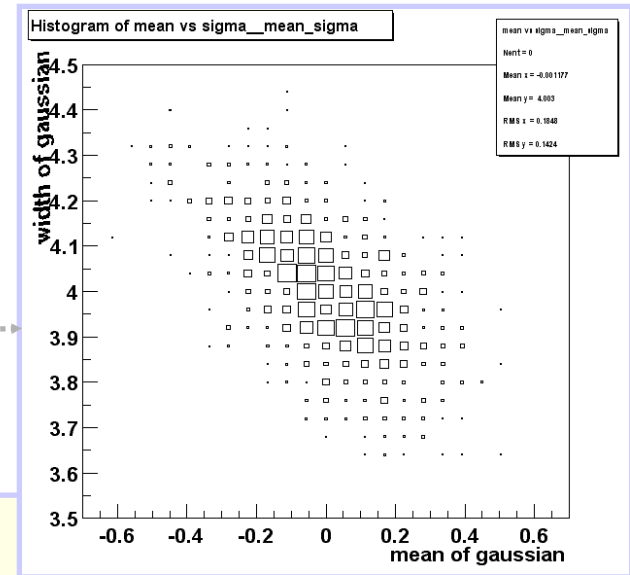

*Pulls and errors  
have separate  
entries for  
easy access  
and plotting*

# A RooMCStudy example

- If the "r" fit option is supplied the RooFitResult output of each fit is be saved

```
mgr.fitResult(10) ->Print("v") ;
```

```
RooFitResult: minimized NLL value: 2585.13, estimated distance to minimum: 3.18389e-06
```

Floating Parameter	InitialValue	FinalValue +/-	Error	GblCorr.
mean	0.0000e+00	1.4814e-01 +/-	1.91e-01	0.597596 <none>
sigma	4.0000e+00	4.0619e+00 +/-	1.43e-01	0.597596 <none>

```
mgr.fitResult(10) ->correlation("sigma") ->Print("v") ;
```

```
RooArgList::C[sigma,*]: (Owning contents)  
1) RooRealVar::C[sigma,mean] : -0.597596 C  
2) RooRealVar::C[sigma,sigma] : 1.0000 C
```

```
RooPlot* frame = new RooPlot(...)  
mgr.fitResult(10) ->plotOn(frame,meanx,  
                             sigmax,"ME12VHB") ;
```

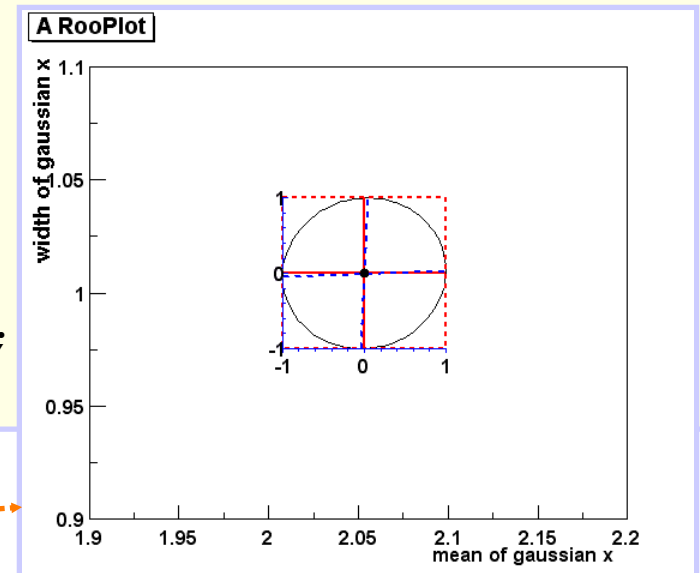

# Fit Validation Study – Practical example

- Example fit model in 1-D (B mass)

- Signal component is Gaussian centered at B mass
- Background component is Argus function (models phase space near kinematic limit)

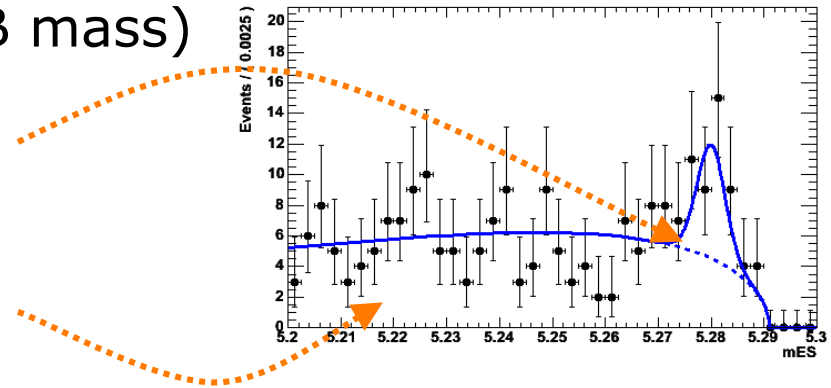

$$F(m; N_{\text{sig}}, N_{\text{bkg}}, \vec{p}_S, \vec{p}_B) = N_{\text{sig}} \cdot G(m; p_S) + N_{\text{bkg}} \cdot A(m; p_B)$$

- Fit parameter under study:  $N_{\text{sig}}$

- Results of simulation study:  
1000 experiments  
with  $N_{\text{SIG}}(\text{gen})=100$ ,  $N_{\text{BKG}}(\text{gen})=200$
- Distribution of  $N_{\text{sig}}(\text{fit})$  .....
- This particular fit looks unbiased...

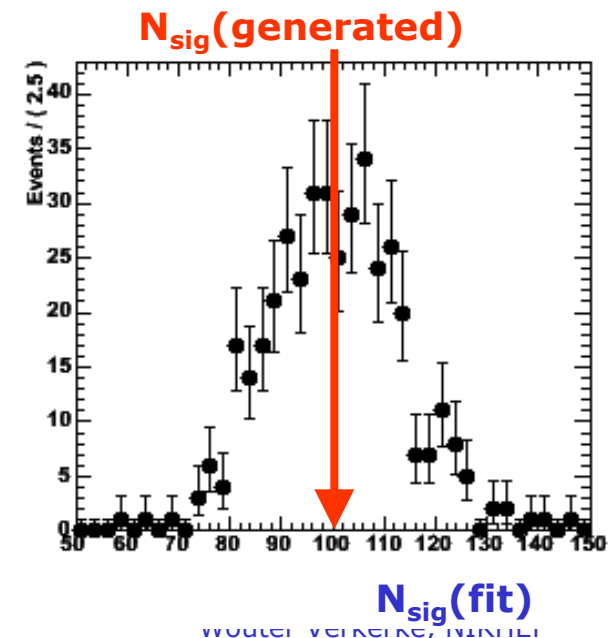

# Fit Validation Study – The pull distribution

- What about the validity of the error?

- Distribution of error from simulated experiments is difficult to interpret...
- We don't have equivalent of  $N_{sig}(\text{generated})$  for the error

- Solution: look at the **pull distribution**

- Definition: 
$$\text{pull}(N_{sig}) = \frac{N_{sig}^{fit} - N_{sig}^{true}}{\sigma_N^{fit}}$$

- Properties of pull:
  - Mean is 0 if there is no bias
  - Width is 1 if error is correct

- In this example: no bias, correct error within statistical precision of study

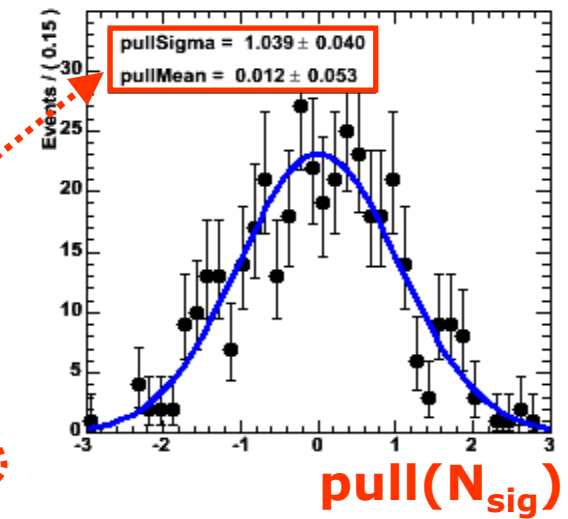
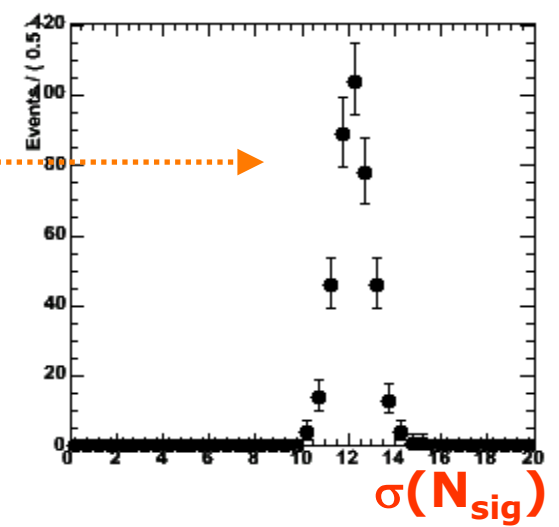

# Fit Validation Study – Low statistics example

---

- Special care should be taken when fitting small data samples
  - Also if fitting for small signal component in large sample
- Possible causes of trouble
  - $\chi^2$  estimators may become approximate as Gaussian approximation of Poisson statistics becomes inaccurate
  - ML estimators may no longer be efficient
    - error estimate from 2<sup>nd</sup> derivative may become inaccurate
  - Bias term proportional to 1/N of ML and  $\chi^2$  estimators may no longer be small compared to 1/sqrt(N)
- In general, **absence of bias, correctness of error can not be assumed**. How to proceed?
  - Use unbinned ML fits only – most robust at low statistics
  - **Explicitly verify the validity of your fit**

# Demonstration of fit bias at low N – pull distributions

- Low statistics example:
  - Scenario as before but now with 200 bkg events and **only 20 signal events** (instead of 100)

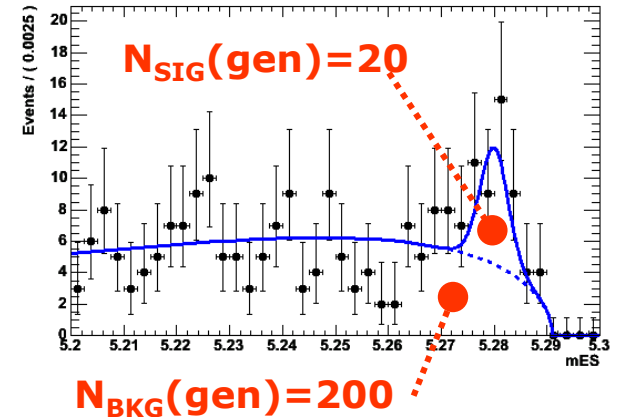

- Results of simulation study

Distributions become asymmetric at low statistics

Pull mean  $\sim 2\sigma$  away from 0  
→ Fit is positively biased!

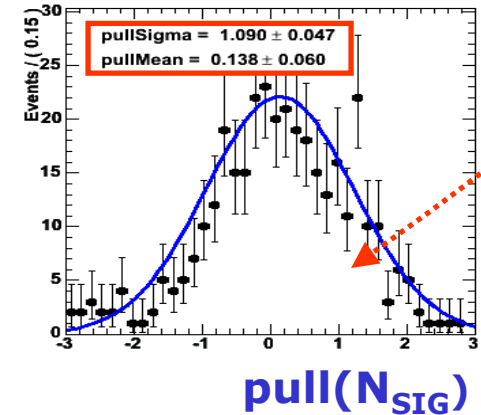
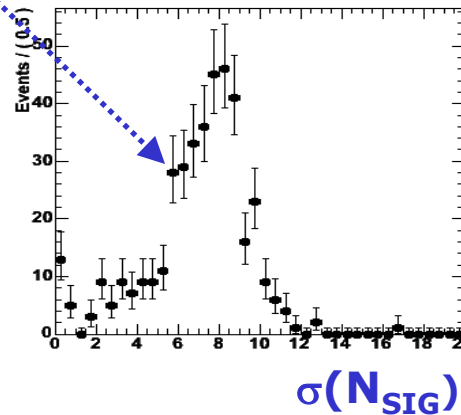
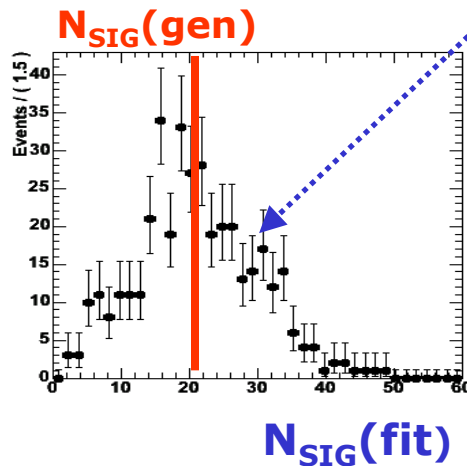

- *Absence of bias, correct error at low statistics not obvious*

# 10 Documentation

# Documentation, Forum and Release plans

---

- Some aspects were not covered for which tools exists
  - E.g. constrained fits, fitting efficiencies, limit calculations
- Sources of documentation
  - Class documentation (updated for ROOT 5.20)
  - Users Manual (being updated, release this summer) 50 pages → 100 pages
  - Tutorial macros (`$ROOTSYS/tutorial/roofit`), 17 now, another 20 forthcoming
- Where to ask (technical) questions
  - ROOT users Forum
- Release schedule
  - ROOT development release 5.21/02 Aug 18, plus every month later up to
  - ROOT production release 5.22, Dec 17
  - Main new developments for 5.21 will be PROOF interfacing for distribution toy MC generation and multi-host fit parallelization